



深圳市拓普微科技开发有限公司

SHENZHEN TOPWAY TECHNOLOGY CO., LTD.

# LM2088RCW

## LCD Module User Manual

Prepared by:  <b>Liqin</b>  Date: 2009-06-22	Checked by:    Date:	Approved by:    Date:
--	----------------------------------	-----------------------------------

Rev.	Descriptions	Release Date
0.1	New release	2009-06-22

## Table of Content

<b>1. Basic Specifications</b> .....	<b>3</b>
1.1 Display Specifications .....	3
1.2 Mechanical Specifications .....	3
1.3 Block Diagram .....	3
1.4 Terminal Functions .....	4
<b>2. Absolute Maximum Ratings</b> .....	<b>5</b>
<b>3. Electrical Characteristics</b> .....	<b>5</b>
3.1 DC Characteristics .....	5
3.2 LED Backlight Circuit Characteristics .....	5
3.3 AC Characteristics .....	6
3.4 Reset Timing .....	6
<b>4. Function Specifications</b> .....	<b>7</b>
4.1 Adjusting the Display Contrast .....	7
4.2 Resetting the LCD module .....	7
4.3 Interfacing Setting .....	7
4.4 Display Pixel Map .....	7
4.5 Control Data and Command .....	8
4.6 Command Summary .....	8
4.7 Initialization Setting Example .....	11
<b>5. Design and Handling Precaution</b> .....	<b>12</b>

# 1. Basic Specifications

## 1.1 Display Specifications

- 1) LCD Display Mode : FSTN, Positive, Transmissive
- 2) Display Color : Display Data = "1" : Dark Gray (\*1)  
: Display Data = "0" : Light Gray (\*2)
- 3) Viewing Angle : 6H
- 4) Driving Method : 1/240 duty, 1/14 bias
- 5) Backlight : White LED backlight

Note:

\*1. Color tone may slightly change by Temperature and Driving Condition.

\*2. The Color is defined as the inactive / background color

## 1.2 Mechanical Specifications

- 1) Outline Dimension : 160.0 x 109.0 x 12.2 MAX.  
see attached Outline Drawing for details

## 1.3 Block Diagram

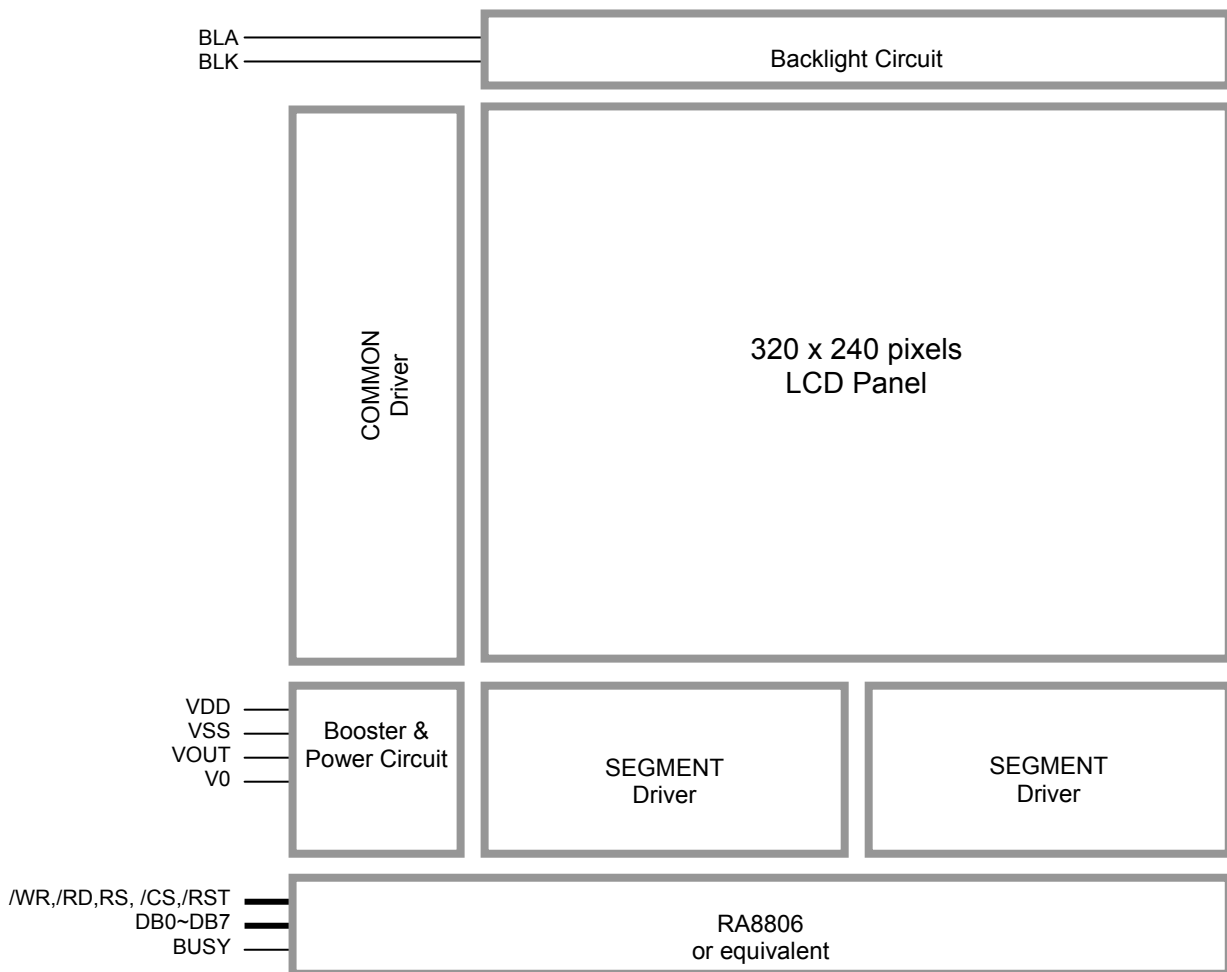

**1.4 Terminal Functions**

Pin No. K1&K2	Pin Name	I/O	Descriptions
1	VSS	Power	0V Power Supply, GND
2	VDD	Power	Positive Power Supply
3	V0	Input	LCD Contrast Reference Input
4	/WR	Input	Write enable input, active LOW
5	/RD	Input	Read enable input, active LOW
6	/CS	Input	Chip Select Signal /CS=LOW: Data IO is enabled
7	RS	Input	Register Select RS=HIGH: status read or command write cycle is selected RS=LOW: data read/write cycle is selected
8	/RST	Input	Reset Signal: /RST = L, Reset the LCD Module /RST = H, Normal Running
9	DB0	I/O	8-bit bi-directional data bus
:	:		
16	DB7		
17	BUSY	Output	Indicate the RA8806 in busy state or not,could been used for MPU to get busy state by connecting it to IO port
18	VOUT	Power	Power Booster Output for V0
19	BLA	Power	Positive Power Supply for LED backlight
20	BLK	Power	Negative Power Supply for LED backlight

note:

\*1. The LCM Fixed to 80 mode by default ,could been changed to 68 mode by changing jumpers

## 2. Absolute Maximum Ratings

Items	Symbol	Min.	Max.	Unit	Condition
Supply Voltage	$V_{DD}$	0	+5.5	V	$V_{SS} = 0V$
Input Voltage	$V_{IN}$	$V_{SS}-0.3$	$V_{DD}+0.3$	V	$V_{SS} = 0V$
Operating Temperature	$T_{OP}$	-20	+70	°C	No Condensation
Storage Temperature	$T_{ST}$	-30	+80	°C	No Condensation

Cautions:

Any Stresses exceeding the Absolute Maximum Ratings may cause substantial damage to the device. Functional operation of this device at other conditions beyond those listed in the specification is not implied and prolonged exposure to extreme conditions may affect device reliability.

## 3. Electrical Characteristics

### 3.1 DC Characteristics

$V_{SS}=0V, V_{DD}=5.0V, T_{OP}=25^{\circ}C$

Items	Symbol	MIN.	TYP.	MAX.	Unit	Applicable Pin
Operating Voltage	$V_{DD}$	4.7	5.0	5.3	V	VDD
Input High Voltage	$V_{IN}$	$0.8 \times V_{DD}$	-	VDD	V	DB0~DB7, /WR, /RD, /CS, RS, /RES
Input Low Voltage	$V_{IN}$	VSS	-	$0.1 \times V_{DD}$	V	DB0~DB7, /WR, /RD, /CS, RS, /RES
LCD Contrast Reference Voltage	$V_0$	-	23.2	-	V	V0
Operating Current	$I_{DD}$	-	22.3	-	mA	VDD

### 3.2 LED Backlight Circuit Characteristics

$BLK=0V, I_{f_{BLA}}=153mA, T_{OP} = 25^{\circ}C$

Items	Symbol	MIN.	TYP.	MAX.	Unit	Applicable Pin
Forward Voltage	$V_{f_{BLA}}$	-	5.0	-	V	BLA
Forward Current	$I_{f_{BLA}}$	-	153	180	mA	BLA

Cautions:

Exceeding the recommended driving current could cause substantial damage to the backlight and shorten its lifetime.

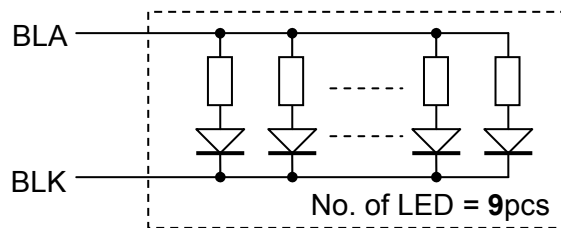

3.3 AC Characteristics

3.3.1 8080 Mode

$V_{SS}=0V, V_{DD}=5.0V, T_{OP}=25^{\circ}C$

Item	Symbol	MIN.	TYP.	MAX.	Unit
System Cycle Time (*2)	t <sub>cyc8</sub>	320	-	-	ns
Strobe Pulse Width	t <sub>cc8</sub>	63	-	-	ns
Address Setup Time	t <sub>as8</sub>	10	-	-	ns
Address Hold Time	t <sub>ah8</sub>	25	-	-	ns
Data Setup Time	t <sub>ds8</sub>	38	-	-	ns
Data Hold Time	t <sub>dh8</sub>	25	-	-	ns
Data Access Time	t <sub>acc8</sub>	-	-	25	ns
Output disable Time	t <sub>oh8</sub>	-	-	13	ns

Note: \*1. Input signal rise/fall time should be less than 20ns  
 \*2. System clock=6MHz  
 \*3. Bus timing is for one byte transaction only.  
 For details, please refer to RA8806 datasheet.

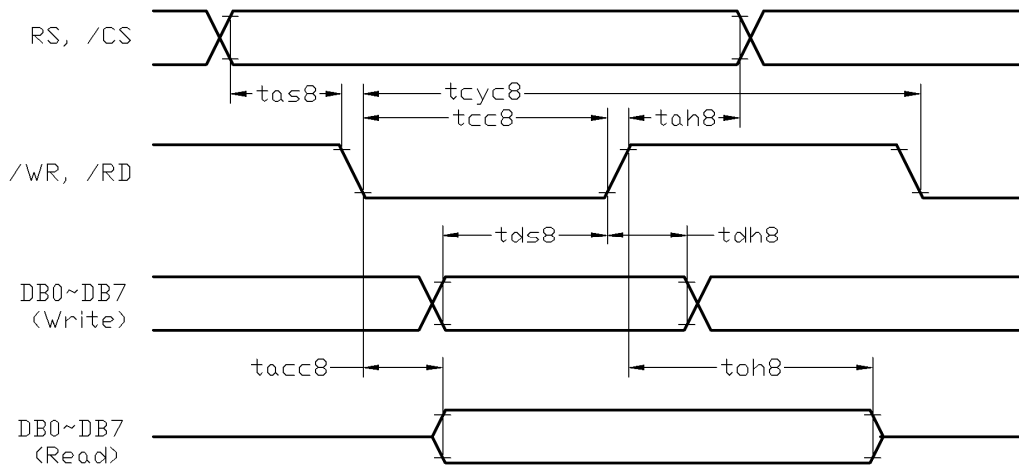

Bus Timing Diagram

3.4 Reset Timing

$V_{SS}=0V, V_{DD}=5.0V, T_{OP}=25^{\circ}C$

Item	Symbol	MIN.	TYP.	MAX.	Unit
Reset setup time	t <sub>rs</sub>	1.3	-	-	ms
Reset hold time	t <sub>rh</sub>	1.3	-	-	ms
Reset active time (*1)	t <sub>rst</sub>	0.2	-	-	us

Note: \*1. System clock=6MHz

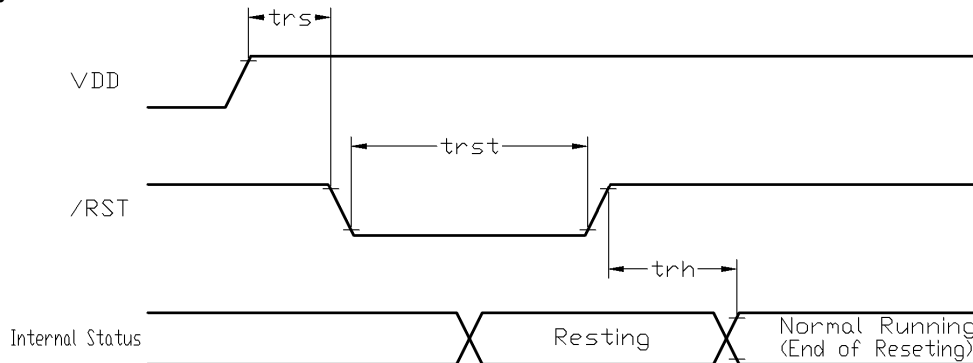

Reset Timing Diagram

## 4. Function Specifications

### 4.1 Adjusting the Display Contrast

A Variable-Resistor must be connected to the LCD module for providing a reference to V0. Adjusting the VR will result the change of LCD display contrast. The recommended value of VR is 25k to 50k

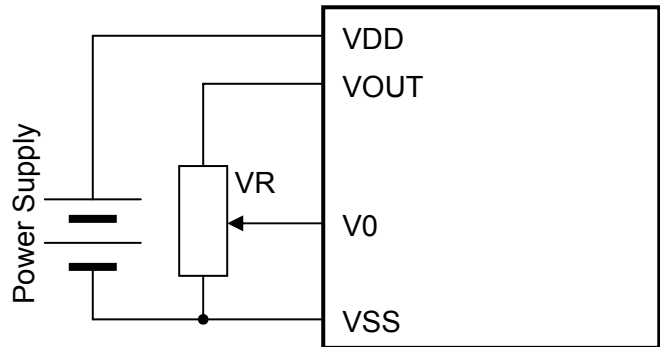

### 4.2 Resetting the LCD module

The LCD module should be initialized by hardware reset, using /RST terminal. While turning on the VDD and VSS power supply, maintain /RST terminal at LOW level. After the power supply stabilized, release the reset terminal (/RST=HIGH)

### 4.3 Interfacing Setting

Jumpers could be used to change bus interfacing family

Jumper				Function Discription
JP6	JP7	JP8	JP9	
open	close	close	open	8080 mode 8 bit selected <default>
close	open	close	open	6800 mode 8 bit selected
close	open	open	close	6800 mode 4 bit selected

### 4.4 Display Pixel Map

1,1 (D7)	2,1 (D6)	3,1 (D5)	4,1 (D4)	5,1 (D3)	---	---	316,1 (D4)	317,1 (D3)	318,1 (D2)	319,1 (D1)	320,1 (D0)
1,2 (D7)	2,2 (D6)	3,2 (D5)	4,2 (D4)	5,2 (D3)	---	---	316,2 (D4)	317,2 (D3)	318,2 (D2)	319,2 (D1)	320,2 (D0)
1,3 (D7)	2,3 (D6)	3,3 (D5)	4,3 (D4)	5,3 (D3)	---	---	316,3 (D4)	317,3 (D3)	318,3 (D2)	319,3 (D1)	320,3 (D0)
:	:	:	:	:	:	:	:	:	:	:	:
1,238 (D7)	2,238 (D6)	3,238 (D5)	4,238 (D4)	5,238 (D3)	---	---	316,238 (D4)	317,238 (D3)	318,238 (D2)	319,238 (D1)	320,238 (D0)
1,239 (D7)	2,239 (D6)	3,239 (D5)	4,239 (D4)	5,239 (D3)	---	---	316,239 (D4)	317,239 (D3)	318,239 (D2)	319,239 (D1)	320,239 (D0)
1,240 (D7)	2,240 (D6)	3,240 (D5)	4,240 (D4)	5,240 (D3)	---	---	316,240 (D4)	317,240 (D3)	318,240 (D2)	319,240 (D1)	320,240 (D0)

Pixel mapping (Top View)

Note:

- \*1. Based on the top view of the LCD module, the 1, 1 (x, y) pixel is the upper-left pixel; the 320, 240 (x, y) pixel is the lower-right pixel.
- \*2. For the details of memory mapping please refer to RA8806 datasheet.

**4.5 Control Data and Command**

The LCD module setting is controlled by the internal Register Values.

The Register Address should be addressed when RS=1 and Register Value should be issued when RS=0.

A full command sequence should be as follow.

Steps	/RD	/WR	RS	Data (DB0~ DB7)
1 <sup>st</sup>	1	0	1	Register Address
2 <sup>nd</sup>	1	0	0	Register Value

**4.6 Command Summary**

Note:

For details please refer to RA8806 datasheet.

Reg. Add	Reg. Name	R/W	D7	D6	D5	D4	D3	D2	D1	D0	Descriptions
--	STATUS	R	MBUSY	SBUSY	SLEEP	--	--	WAKE_STS	KS_STS	TP_STS	<b>MBUSY:Memory Write Busy Flag</b> 1=Busy when write font or clear RAM; 0=not busy <b>SBUSY:Scan Busy Flag</b> 1=Busy when driver scan logic is not idle; 0=not busy <b>SLEEP:Sleep state</b> 1= In Sleep mode; 0=In Normal mode <b>WAKE_STS:Wakeup Status Bit</b> Same as REG[0FH] Bit2 <b>KS_STS:Key Status Bit</b> Same as REG[0FH] Bit1 <b>TP_STS:Tp Status Bit</b> Same as REG[0FH] Bit0
00h	WLCR	R/W	PWR	LINER	SR	--	CG	DP	BK	DV	<b>PWR : Power Mode</b> 1=In Sleep Mode; 0=In Normal Mode <b>LINER:linear Decode Mode</b> 1=User-defined ROM mapping rule; 0=GIG5/GB ROMmapping rule <b>SR : Software Reset</b> 1=reset all register (except DDRAM); 0=normal operation <b>CG : Display mode selection</b> 1=Character Mode; 0=Graphic Mode <b>DP : Display on off control</b> 1=normal display; 0=display off <b>BK : Full screen blinking control</b> 1=blinking (blink time is set by REG 80H); 0=normal; <b>DV : Full screen inverse control</b> 1=Inverse Full Screen; 0=Normal
01h	MISC	R/W	NO_FLICKER	CKN	BUSY_LEV	INT_LEV	XCK_SEL1	XCK_SEL0	SDIR	CDIR	<b>NO_FLICKER : Eliminating Flicker</b> 1=enable,scan will auto-pending when busy; 0=disable <b>CKN : Clock Output in pin CLK_OUT</b> 1=The pin indicates SLEEPstate of STATUS REG; 0=The pin output internal system clock <b>BUSY_LEV : Busy Polarity(for "BUSY" pin)</b> 1=Set Active High; 0=Set Active Low <b>INT_LEV:Interrupt Polarty(for "INT" pin)</b> 1=Set Active High; 0=Set Active Low <b>XCK_SEL[1:0] : Driver Clock Selection</b> 00=CLK/8; 01=CLK/4(Default); 10=CLK/2; 11=CLK The CLK means system clock <b>SDIR:SEG Scan Direction</b> 1=SEG order is 319~0; 0=SEG order is 0~319 <b>CDIR: COM Scan Direction</b> 1=COM order is 239~0; 0=COM order is 0~239
03h	ADSR	R/W	SCR_PEND	--	--	--	BIT_INV	SCR_DIR	SCR_HV	SCR_EN	<b>SCR_PEND : scroll Function Pending</b> 1=Scroll function pending; 0=Scroll function keep active <b>BIT_INV : Set driver data output BIT Order</b> 1=inverse order (BIT7 to BIT0, BIT6 to BIT1, and so on); 0=Normal order <b>SCR_DIR : Scroll Direction</b> When SCR_HV=1, 1= Bottom -> Top; 0= Top -> Bottom When SCR_HV=0, 1=Right -> Left; 0=Left -> Right <b>SCR_HV : Scroll Horizontal/Vertical Selection</b> 1= Common Scrolling(Vertical); 0= Segment Scrolling(Horizontal) <b>SCR_EN : Scroll Enable</b> 1=Scroll function enable; 0=Scroll function disable



Register Table Summary (cont')

Reg. Add	Reg. Name	R/W	D7	D6	D5	D4	D3	D2	D1	D0	Descriptions
0FH	INTR	R/W	-	WAKI_EN	KEYI_EN	TPI_EN	TP_ACT	WAK_STS	KEY_STS	TP_STS	<p><b>WAKI_EN : Wakeup Interrupt Mask</b> 1=enable ; 0=disable</p> <p><b>KEYI_EN : Key-Scan Interrupt Mask</b> 1=enable ; 0=disable</p> <p><b>TPI_EN : Touch Panel Interrupt Mask</b> 1=Generate interrupt output if TP was detected; 0=disable</p> <p><b>TP_ACT : Touch Panel Event (only read)</b> 1=TP is touched;0=TP is not touched</p> <p><b>WAK_STS : Wakeup Interrupt Status bit</b> 1=Indicate wake-up event happen from Sleep mode 0=Indicate no wake-up happen User must write 0 to clear the status bit</p> <p><b>KEY_STS : Key-Scan Interrupt Status bit</b> 1=Key-Scan Detect Key input; 0=Key-Scan don't Detect key input User must write 0 to clear the status bit</p> <p><b>TP_STS : Touch Panel Detect Status bit</b> 1= TP touched; 0=TP untouched User must write 0 to clear the status bit</p>
10h	WCCR	R/W	CUR_INC	FULL_OFS	BIT_REV	BOLD	T90DEG	CUR_EN	CUR_BLK	-	<p><b>CUR_INC : Auto-increase Cursor Position in reading/writing DDRAM operation</b> 1=disable; 0=enable</p> <p><b>FILL_OFS: Full-size and Half-size Character Alignment</b> 1=Full-size alignment in Full-size and Half-size mixed mode; 0=disable</p> <p><b>BIT_REV : Reversed Data Write mode</b> 1= invertly; 0= directly</p> <p><b>BOLD : Set Bold font (char mode only)</b> 1=bold; 0=normal</p> <p><b>T90DEG : Font Rotate mode (Font rotaed 90 degree)</b> 1=enable; 0=normal</p> <p><b>CUR_EN : Cursor display control</b> 1=on; 0=off</p> <p><b>CUR_BLK : Cursor blink control</b> 1=blinking; 0=normal (Blink time is determined by REG 80H)</p>
11h	CHWI	R/W	CURH3	CURH2	CURH1	CURH0	ROWH3	ROWH2	ROWH1	ROWH0	<p><b>CURH[3:0] : Cursor Height (Vertical direction, horizontal is fix)</b> 0000b : Cursoer height 1pixel 0001b : Cursor height 2 pixels ..... 1111b : Cirsor height 16 pixels</p> <p><b>ROWH[3:0] : Char Line Gap</b> 0000b : Char LineGap 1pixel 0001b : Char LineGap 2 pixels ..... 1111b : Char LineGap 16 pixels</p>
12h	MAMR	R/W	CUR_HV	DISPMD2	DISPMD1	DISPMD0	L_MIX1	L_MIX0	MW_MD1	MW_MD0	<p><b>CUR_HV : Cursoer Auto Shifting Direction(only Graphic Mode)</b> 1= Vertical then Horizontal; 0= Horizontal then Vertical</p> <p><b>DISPMD[2:0] : Display Layer and Display Mode Selection</b> 001=page1 only(default); 010=page2 only; 011=combine two layer; 000=gray scale mode 110=extended mode1, 111=extended mode2</p> <p><b>L_MIX[1:0] : two layer mode setting</b> 00=OR; 01=XOR; 10=NOR; 11=AND</p> <p><b>MW[1:0] : Layer Read/Write Selection</b> 00=CGRAM(512Byte); 01=page1; 10=page2; 11=page1 &amp; page2 at the same time</p>
20h	AWRR	R/W	-	-	AWR5	AWR4	AWR3	AWR2	AWR1	AWR0	<p><b>AWR[5:0] : Active Window Right Position -&gt;Segment-Right</b> Default Value:27h</p>
21h	DWRR	R/W	-	-	DWW5	DWW4	DWW3	DWW2	DWW1	DWW0	<p><b>DWW[5:0] : Display Window Width Position -&gt; Segment-Width</b> Segment-Width = (Segment Number / 8) – 1 Default Value:27h</p>
30h	AWBR	R/W	AWB7	AWB6	AWB5	AWB4	AWB3	AWB2	AWB1	AWB0	<p><b>AWT[7:0] : Active Window Bottom Position-&gt;Common-Bottom</b> Default Value:efh</p>
31h	DWHR	R/W	DWH7	DWH6	DWH5	DWH4	DWH3	DWH2	DWH1	DWH0	<p><b>DWH[7:0] : Display Window Bottom Position-&gt;Common-Height</b> Common-Height = LCD Common Number – 1 Default Value:efh</p>

Register Table Summary (cont')

Reg. Add	Reg. Name	R/W	D7	D6	D5	D4	D3	D2	D1	D0	Descriptions
A1h <i>(not applicable)</i>	KSCR	R/W	KEN	KSZ	KDT1	KDT0	--	KF2	KF1	KF0	<b>KEN : Key Scan Enable Bit</b> 1=enable; 0=disable <b>KSZ : Key Scan Matrix Selection</b> 1=4x4; 0=8x8 <b>KDT1~KDT0 : Key Scan Data Sampling Times</b> 00=2xFRM; 01=4xFRM; 10=8xFRM; 11=16xFRM <b>KF2~KF0 : Key Scan Frequency Selection</b> 000= 2xFRM, 001=4xFRM; 010=8xFRM; 011=16xFRM 100= 32xFRM, 001=64xFRM; 010=128xFRM; 011=256xFRM
A2h <i>(not applicable)</i>	KSDR	R	KC7	KC6	KC5	KC4	KC3	KC2	KC1	KC0	<b>KC7~KC0 : Key Scan Output</b>
A3h <i>(not applicable)</i>	KSER	R	KR7	KR6	KR5	KR4	KR3	KR2	KR1	KR0	<b>KR7~KR0 : Key Scan Data Input</b>
B0h <i>(not applicable)</i>	INTX	R/W	--	--	IX5	IX4	IX3	IX2	IX1	IX0	<b>IX5~IX0 : Interrupt Column Setup Register</b>
B1h <i>(not applicable)</i>	INTY	R/W	IY7	IY6	IY5	IY4	IY3	IY2	IY1	IY0	<b>IY7~IY0 : Interrupt Row Setup Register</b>
C0h <i>(not applicable)</i>	TPCR	R/W	AZEN	AZOE	--	SCAN	AS3	AS2	AS1	AS0	<b>AZEN : Touch Panel Function</b> 1=enable; 0=disable <b>AZOE : Touch Panel Data Output</b> 1=enable; 0=disable <b>SCAN : Touch Panel Scan</b> 1=enable; 0=disable <b>AS3~AS0 : Touch Panel Control Bits</b>
C1h <i>(not applicable)</i>	TPSR	R/W	ARDY	ADET	1	1	AF1	FA0	--	--	<b>ARDY : ADC Data Convert State</b> 1=convert complete; 0=convert incomplete <b>ADET : Touch Event Indicate</b> 1=touched; 0=untouched
C8h <i>(not applicable)</i>	TPXR	R	TPX9	TPX8	TPX7	TPX6	TPX5	TPX4	TPX3	TPX2	<b>TPX9~TPX2 : Touch Panel Segment data D9~D2</b>
C9h <i>(not applicable)</i>	RPYR	R	TPY9	TPY8	TPY7	TPY6	TPY5	TPY4	TPY3	TPY2	<b>TPY9~TPY2 : Touch Panel Common data D9~D2</b>
CAh <i>(not applicable)</i>	TPZR	R	TPX1	TPX0	--	--	TPY1	TPY0	--	--	<b>TPX1~TPX0 : Touch Panel Segment data D1~D0</b> <b>TPY1~TPY0 : Touch Panel Common data D1~D0</b>
D0h	LCCR	R/W	DZEN	--	--	DAC4	DAC3	DAC2	DAC1	DAC0	<b>DZEN : LCD contrast control</b> 1=disable; 0=enable <b>DAC4~DAC0 : LCD Contrast Control Value</b>
E0h	PNDR	R/W	FD7	FD6	FD5	FD4	FD3	FD2	FD1	FD0	<b>FD7~FD0 : Pattern Data Register / Display Times of Gray Mode</b>
F0h	FNCR	R/W	TNS	BNK	RM1	RM0	FDA	ASC	ABS1	ABS0	<b>TNS : External Char ROM</b> 1=enable; 0=disable <b>BNK : ROM BANK Selection</b> 1=Lower 256k ROM; 0=upper 256k ROM <b>RM1~RM0 : Font ROM Translate</b> 00=GB(256k); 01=BIG5(512k); 10=GB(512k) <b>FDA : Fill Data to DDRAM</b> 1=fill data to DDRAM enable; 0=no action; <b>ASC : Font ROM range select</b> 1=decode as ASCII; 0=auto <b>ABS1~ABS0 : ASCII Block Selection</b> 00=map to ASCII block 0; 01=map to ASCII block 1; 10=map to ASCII block 2; 11=map to ASCII block 3
F1h	FVHT	R/W	FH1	FH0	FV1	FV0	1	1	1	1	<b>FH1~FV0 : Font Horizontal Size</b> 00=1x; 01=2x; 10=3x; 11=4x <b>FV1~FV0 : Font Vertical Size</b> 00=1x; 01=2x; 10=3x; 11=4x

Note:

- \*1. It is suggested to check the BUSY before sending the Control Data.
- \*2. For the details, please refer to RA8806 Data sheet.

#### 4.7 Initialization Setting Example

The following setting should be issue to LCD module after hardware reset.  
(example could be adjusted, if necessary.)

Register Add	Register Name	Value (binary)	Value (hex)	Note
00h	WLCR	0000 0100	04	Power Mode = Normal Mode Software Reset = Normal Operation Display mode = Graphical Mode Display on Full screen blinking control = normal (no blinking) Full screen inverse = normal (no inverse)
01h	MISC	0110 1000	68	Eliminating Flicker = normal Busy is High active XCK = CLK/2 SEG/COM order are normal order
03h	ADSR	0000 0000	00	Scrolling function is disable
0Fh	INTR	0000 0000	00	Set interrupts are disable
10h	WCCR	0000 0110	06	Auto-increase Cursor Position Chinese/English char alignment = disable Store Current Data to DDRAM = directly Set Bold font (char mode only) = normal Font rotae mode = disable Cursor on Cursor blink
11h	DWLR	1110 0000	E0	Cursor Height = 15 pixels Line Distance = 1 pixel
20h	AWRR	0010 0111	27	Active Window Right Register = 40
21h	DWRR	0010 0111	27	Display Window Right Register = 40
30h	AWBR	1110 1111	EF	Active Window Bottom Register = 240
31h	DWBR	1110 1111	EF	Display Window Bottom Register = 240
40h	AWLR	0000 0000	00	Active Window Left Register = 00
50h	AWTR	0000 0000	00	Active Window Top Register = 00
90h	SCCR	0110 1010	6A	Idle Time set (set to ~66Hz, when system clock=6MHz)
F0h	FNCR	1000 0000	80	Memory Clear Function = no action
F1h	FVHT	0000 0000	00	Font is normal

Note:

Others un-mentioned registers are using its hardware reset default value.

## 5. Design and Handling Precaution

1. The LCD panel is made by glass. Any mechanical shock (eg. dropping from high place) will damage the LCD module.
2. Do not add excessive force on the surface of the display, which may cause the Display color change abnormally.
3. The polarizer on the LCD is easily get scratched. If possible, do not remove the LCD protective film until the last step of installation.
4. Never attempt to disassemble or rework the LCD module.
5. Only Clean the LCD with Isopropyl Alcohol or Ethyl Alcohol. Other solvents (eg. water) may damage the LCD.
6. When mounting the LCD module, make sure that it is free from twisting, warping and distortion.
7. Ensure to provide enough space (with cushion) between case and LCD panel to prevent external force adding on it, or it may cause damage to the LCD or degrade the display result.
8. Only hold the LCD module by its side. Never hold LCD module by add force on the heat seal or TAB.
9. Never add force to component of the LCD module. It may cause invisible damage or degrade of the reliability.
10. LCD module could be easily damaged by static electricity. Be careful to maintain an optimum anti-static work environment to protect the LCD module.
11. When peeling off the protective film from LCD, static charge may cause abnormal display pattern. It is normal and will resume to normal in a short while.
12. Take care and prevent get hurt by the LCD panel sharp edge.
13. Never operate the LCD module exceed the absolute maximum ratings.
14. Keep the signal line as short as possible to prevent noisy signal applying to LCD module.
15. Never apply signal to the LCD module without power supply.
16. IC chip (eg. TAB or COG) is sensitive to the light. Strong lighting environment could possibly cause malfunction. Light sealing structure casing is recommend.
17. LCD module reliability may be reduced by temperature shock.
18. When storing the LCD module, avoid exposure to the direct sunlight, high humidity, high temperature or low temperature. They may damage or degrade the LCD module