



深圳市拓普微科技开发有限公司

SHENZHEN TOPWAY TECHNOLOGY CO., LTD.

LM32019CFW

LCD Module User Manual

Prepared by: K.C. Date:	Checked by: Date:	Approved by: Date:
--	----------------------------------	-----------------------------------

Rev.	Descriptions	Release Date
0.1	Preliminary new release	2008-05-08
0.2	Update display on /off control bit on 4.3.3 Registers Table	2008-09-01

Table of Content

1. Basic Specifications	3
1.1 Display Specifications	3
1.2 Mechanical Specifications	3
1.3 Block Diagram.....	3
1.4 Terminal Functions.....	4
2. Absolute Maximum Ratings	5
3. Electrical Characteristics	5
3.1 DC Characteristics	5
3.2 LED Backlight Circuit Characteristics	5
3.3 AC Characteristics	6
4. Function Specifications	7
4.1 Adjusting the Display Contrast	7
4.2 Display Pixel Map (4Gray Scale).....	7
4.3 Command Packet Format	8
5. Design and Handling Precaution	14

1. Basic Specifications

1.1 Display Specifications

- 1) LCD Display Mode : STN, Negative, Transmissive
- 2) Display Color : Display Data = "11" : Light Gray (*1)
: Display Data = "00" : Dark Blue (*2)
- 3) Driving Method : 1/240 duty, 1/16 bias
- 4) Backlight : White LED backlight

Note: *1. Color tone may slightly change by Temperature and Driving Condition.
*2. The Color is defined as the inactive / background color

1.2 Mechanical Specifications

- 1) Outline Dimension : 159.0 x 107.8 x 11.0 MAX.
see attached Outline Drawing for details

1.3 Block Diagram

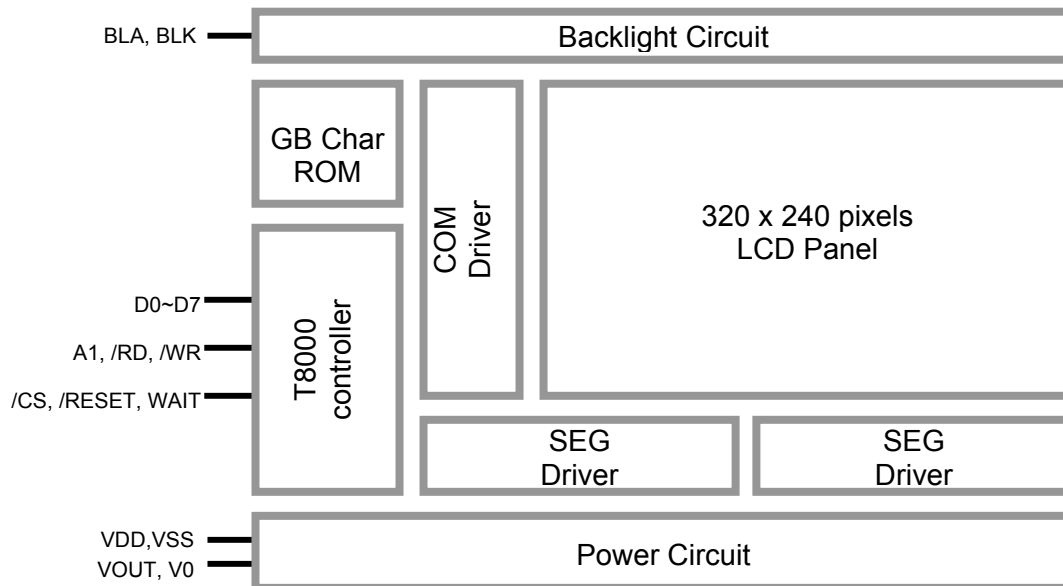

1.4 Terminal Functions

Pin No.	Pin Name	I/O	Descriptions
1	VSS	Power	0V Power Supply, GND
2	VDD	Power	Positive Power Supply
3	V0	Input	LCD Contrast Reference Input
4	/WR	Input	Write enable input, active LOW
5	/RD	Input	Read enable input, active LOW
6	/CS	Input	Chip Select Inputs /CS=LOW: Data IO is enabled
7	A1	Input	Register Select A1=LOW: Address[F004] is being accessed Command Packet Port for Writing of Command Packets A1=HIGH: Address[F006] is being accessed Port for writing Control or reading status
8	/RESET	Input	Reset Signal Input /RESET=LOW: Reset /RESET=HIGH: Normal
9	D0	I/O	8-bit bi-directional data bus
:	:	:	
16	D7	I/O	
17	/WAIT	Output	Wait signal
18	VOUT	Output	DC/DC power output for V0
19	BLA	Power	Positive Power Supply for LED backlight
20	BLK	Power	Negative Power Supply for LED backlight

2. Absolute Maximum Ratings

Items	Symbol	Min.	Max.	Unit	Condition
Supply Voltage	V_{DD}	-0.3	+3.3	V	$V_{SS} = 0V$
Input Voltage	V_{IN}	-0.3	+5.5	V	$V_{SS} = 0V$
Operating Temperature	T_{OP}	-20	70	°C	No Condensation
Storage Temperature	T_{ST}	-30	80	°C	No Condensation

Cautions:

Any Stresses exceeding the Absolute Maximum Ratings may cause substantial damage to the device. Functional operation of this device at other conditions beyond those listed in the specification is not implied and prolonged exposure to extreme conditions may affect device reliability.

3. Electrical Characteristics

3.1 DC Characteristics

$V_{SS}=0V, V_{DD} =3.3V, T_{OP} =25^{\circ}C$

Items	Symbol	MIN.	TYP.	MAX.	Unit	Applicable Pin
Operating Voltage	V_{DD}	3.0	3.3	3.6	V	VDD
Input High Voltage	V_{IH}	3.0	-	VDD	V	Input pins, Bi-direction pins
Input Low Voltage	V_{IL}	VSS	-	0.6	V	Input pins, Bi-direction pins
Output High Voltage	V_{OH}	2.6	-	-	V	Bi-direction pins (*1)
Output Low Voltage	V_{OL}	-	-	0.6	V	Bi-direction pins (*2)
LCD Contrast Reference Voltage	V_0	-	22.9	-	V	V0
Operating Current(*3)	I_{DD}	-	42.5	TBD	mA	VDD

Note:

*1. $I_{OH}=-3.0mA$

*2. $I_{OL}= 3.0mA$

3.2 LED Backlight Circuit Characteristics

$BLK=0V, I_{f_{BLA}}=220mA, T_{OP} =25^{\circ}C$

Items	Symbol	MIN.	TYP.	MAX.	Unit	Applicable Pin
Forward Voltage	$V_{f_{BLA}}$	-	3.3	-	V	BLA
Forward Current	$I_{f_{BLA}}$	-	220	300	mA	BLA

Cautions:

Exceeding the recommended driving current could cause substantial damage to the backlight and shorten its lifetime.

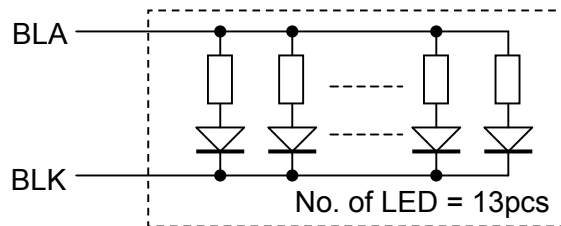

3.3 AC Characteristics

3.3.1 Write Timing

$V_{SS}=0V, V_{DD}=3.3V, T_{OP}=25^{\circ}C$

Symbol	Parameter	Min	Max	Unit
t_{OHZ}	Output Disable to Data Output in High-Z	0	15	ns
t_{AS}	Address Setup Time	15	-	ns
t_{WP}	Write Pulse Width	160	-	ns
t_{CW}	Chip Select Assertion to Write Assertion	0	-	ns
t_{WC}	Write Negation to Chip Select Negation	0	-	ns
t_{WR}	Write Recovery Time	80	-	ns
t_{DS}	Write Data to Write Assertion Setup	0	-	ns

Note: T_{RISE} and T_{FALL} for all inputs must be ≤ 5 nsec (10% - 90%)

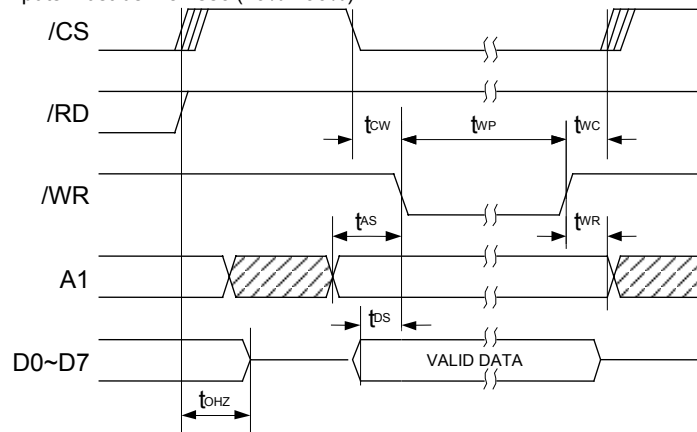

Host Interface - Write Timing Diagram
(for registers 0xF004 & 0xF006 only)

3.3.2 Read Timing

$V_{SS}=0V, V_{DD}=3.3V, T_{OP}=25^{\circ}C$

Symbol	Parameter	Min	Max	Unit
t_{CR}	Chip Select Assertion to Read Assertion	0	-	ns
t_{RC}	Read Negation to Chip Select Negation	0	-	ns
t_{AS}	Address Setup Time	15	-	ns
t_{RP}	Read Pulse Width	160	-	ns
t_{AH}	Address Hold Time to Read Negation	80	-	ns
t_{OLZ}	Read to Output in Low-Z	5	-	ns
t_{AC}	Access Time	-	18	ns
t_{OHZ}	Output Disable to Data Output in High-Z	0	13	ns

Note: T_{RISE} and T_{FALL} for all inputs must be ≤ 5 nsec (10% - 90%)

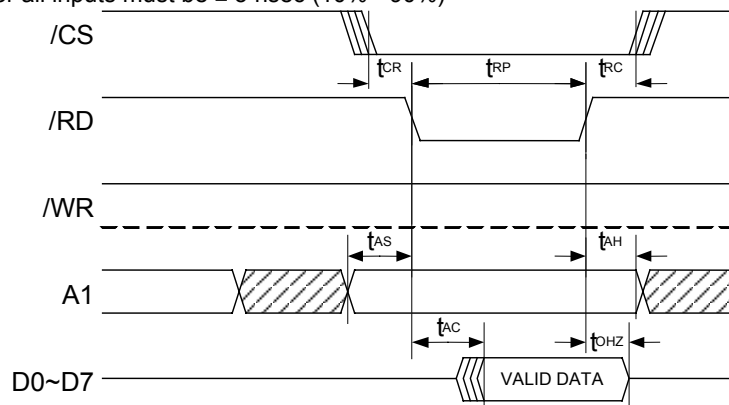

Read Cycle asserted.
(for registers 0xF004 & 0xF006 only)

4. Function Specifications

4.1 Adjusting the Display Contrast

A Variable-Resistor must be connected to the LCD module for providing a reference to V0. Adjusting the VR will result the change of LCD display contrast. The recommended value of VR is 25k to 50k

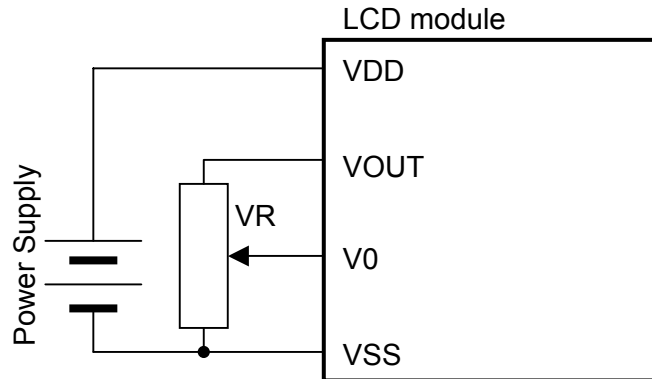

4.2 Display Pixel Map (4 Gray Scale)

1,1 (D7,D6)	2,1 (D5,D4)	3,1 (D3,D2)	4,1 (D1,D0)	5,1 (D7,D6)	---	---	316,1 (D1,D0)	317,1 (D7,D6)	318,1 (D5,D4)	319,1 (D3,D2)	320,1 (D1,D0)
1,2 (D7,D6)	2,2 (D5,D4)	3,2 (D3,D2)	4,2 (D1,D0)	5,2 (D7,D6)	---	---	316,2 (D1,D0)	317,2 (D7,D6)	318,2 (D5,D4)	319,2 (D3,D2)	320,2 (D1,D0)
1,3 (D7,D6)	2,3 (D5,D4)	3,3 (D3,D2)	4,3 (D1,D0)	5,3 (D7,D6)	---	---	316,3 (D1,D0)	317,3 (D7,D6)	318,3 (D5,D4)	319,3 (D3,D2)	320,3 (D1,D0)
:	:	:	:	:	:	:	:	:	:	:	:
1,238 (D7,D6)	2,238 (D5,D4)	3,238 (D3,D2)	4,238 (D1,D0)	5,238 (D7,D6)	---	---	316,238 (D1,D0)	317,238 (D7,D6)	318,238 (D5,D4)	319,238 (D3,D2)	320,238 (D1,D0)
1,239 (D7,D6)	2,239 (D5,D4)	3,239 (D3,D2)	4,239 (D1,D0)	5,239 (D7,D6)	---	---	316,239 (D1,D0)	317,239 (D7,D6)	318,239 (D5,D4)	319,239 (D3,D2)	320,239 (D1,D0)
1,240 (D7,D6)	2,240 (D5,D4)	3,240 (D3,D2)	4,240 (D1,D0)	5,240 (D7,D6)	---	---	316,240 (D1,D0)	317,240 (D7,D6)	318,240 (D5,D4)	319,240 (D3,D2)	320,240 (D1,D0)

Pixel mapping (Top View)

Note:

- *1. Based on the top view of the LCD module, the 1, 1 (x, y) pixel is the upper-left pixel; the 320, 240 (x, y) pixel is the lower-right pixel.
- *2. For the details of memory mapping please refer to T8000 datasheet.
- *3. For 4 Gray Scale (2bpp) mode, the data arrangement [D(i),D(i-1)] represent one pixel.

4.3 Commands and Registers

4.3.1 Command Packet Format

All commands are organized in packet with a 1 byte “Opcode” followed by optional parameters / data.

	Steps	A1	/RD	/WR	Data	Descriptions
Up to 64byte ↑ ↓	1	0	1	0	Opcode	Command Opcode
	2	0	1	0	Parameter	Parameter / Data
	⋮	⋮	⋮	⋮	⋮	⋮
	⋮	⋮	⋮	⋮	⋮	⋮
	:	1	1	0	01(hex)	Command End, Display On

- For matching the FIFO size, the command packet should not larger than 64byte (exclude, the Command End)
- For multi-byte parameter/data, send LSB (low byte)first, MSB (highest byte) last.

4.3.2 Opcode Description

Opcode (HEX)	Operations	Parameters / Data
00	Set “Control & Status Port” of the Command Interpreter	The value of this data (one byte) will be directly written to the Control & Status register.
10	charset_config	Character Set (1 byte): 00: Built in 8x8 ASCII 01: 8x8 CGRAM (Embedded RAM) 02: 8x16 CGRAM (Embedded RAM) 03: 16x16 CGRAM (Embedded RAM) 04: 16x16 GB2312-80 (External ROM)
12	set_print_coord	Character Print Coordinates (4 bytes) - x (2 bytes) - y (2 bytes) For 4GS, x = (multiple of 2) – 1 For 16GS, x = (multiple of 4) – 1
14	set_font_fgcolor	Character Foreground Color (2 bytes) (same as td_fgcolor, with opcode = (20 HEX)) For 4GS: 2bpp, (0x0000 ~ 0x0003) For 16GS: 4bpp (0x0000 ~ 0x000F)
15	set_font_bgcolor	Character Background Color (2 bytes) For 4GS: 2bpp, (0x0000 ~ 0x0003) For 16GS: 4bpp (0x0000 ~ 0x000F)

Opcode (HEX)	Operations	Parameters / Data
16	show_char	Display Character (1 or 2 bytes)
17	show_string	Display String - Character count (1 byte) ($0 \leq \text{character count} \leq 63$) - String (≤ 63 bytes)
20	td_fgcolor	Set Foreground Color (2 bytes) For 4GS: 2bpp, (0x0000 ~ 0x0003) For 16GS: 4bpp (0x0000 ~ 0x000F)
23	draw_pixel	Draw Pixel - x (2 bytes) - y (2 bytes)
24	draw_line	Draw Line - x_start (2 bytes) - y_start (2 bytes) - x_end (2 bytes) - y_end (2 bytes)
26	draw_rect	Draw Hollow Rectangle (Box) - x_start (2 bytes) - y_start (2 bytes) - x_end (2 bytes) - y_end (2 bytes)
27	fill_rect	Fill Rectangle (Box) - x_start (2 bytes) - y_start (2 bytes) - x_end (2 bytes) - y_end (2 bytes)
28	draw_circle	Draw Circle - x_center (2 bytes) - y_center (2 bytes) - radius (1 byte)
29	fill_circle	Fill Circle - x_center (2 bytes) - y_center (2 bytes) - radius (1 byte)
81	set_mem_ptr	Set memory pointer - address (3 bytes)
82	read_reg	Read register - address (2 bytes) ONLY used in RS232 serial host mode
83	write_reg	Write register - address (2 bytes) - data (1 byte)
84	write_mem	Write memory - count (1 byte) - data (up to 63 bytes)
8F	mem_clk_en	Enable memory clock "69 45 61 67 6C 65" (6 bytes in HEX)

4.3.3 Registers Table

Register (HEX)	R/W	Reset Value	Descriptions
F000	Read Write	1000 0000	Chip ID Port Always read back <u>80 (HEX)</u> Write "DE FC 0B" (HEX) to enable memory clock, same as command with OPCODE "8F".
F001	Read only	0000 0000	Chip Revision Port Always read back <u>00 (HEX)</u> for iEM8000
F004	Write only	-	Command Packet Port - Writing of Command Packets.
F006	Write Read	Don't Care Bit[3] = 1 Don't Care Bit[0] = 0 Don't Care Bit[0] = 0	Port for writing control or reading status Bit[7:4]: Reserved Bit[3]: DISPLAY ON / OFF 0 : DISPLAY ON 1 : DISPLAY OFF Bit[2:1]: Reserved Bit[0]: End of Command Write "1" after each command packet Bit[7:1]: Reserved Bit[0]: FIFO full Read "1" if Command FIFO is full. Hosts must read this bit = "0" before writing to Command Packet Port.
F080	Read / Write	0000 0000	Bit[7:6]: External SRAM Select Bit[7:6] = 11: Required setting - 64Kx16 external SRAM connected Bit[5]: Horizontal TFT Pulse Polarity 0: Active low 1: Active high Bit[4]: Vertical TFT Pulse Polarity 0: Active low 1: Active high Bit[3]: STN Panel I/F Data Width 0: 4-bit single 1: 8-bit single Bit[2]: Color Mode Select 0: Monochrome 1: Color Bit[1:0]: Color Depth Select If Monochrome (Bit[2] = 0) 00: 1 bit-per-pixel 01: 2 bit-per-pixel 10: 4 bit-per-pixel 11: Reserved If Color (Bit[2] = 1) 00: 16 bit-per-pixel (TFT panel) 01: 12 bit-per-pixel (CSTN panel) 10: Reserved 11: Reserved
F081	Read / Write	000 0000	Bit[7]: Reserved Bit[6:0]: Panel Horizontal Character Count – 1, Panel Horizontal Character Count[8:0] supports horizontal panel size up to 128 characters or 1024 pixels.
F082	Read / Write	0000 0000	Bit[7:0]: Panel Line Count - 1 bit[7:0]
F083	Read / Write	0	Bit[7:1]: Reserved Bit[0]: Panel Line Count – 1 bit[8], Panel Line Count[8:0] supports vertical panel size up to 512 lines.
F084	Read / Write	0000 0000	Bit[7:0]: Display Start Position X Coordinate – 1 bit[7:0]
F085	Read / Write	00	Bit[7:2]: Reserved Bit[1:0]: Display Start Position X Coordinate – 1 bit[9:8]

Register (HEX)	R/W	Reset Value	Descriptions
F086	Read / Write	0000 0000	Bit[7:0] Display Start Position Y Coordinate – 1 bit[7:0]
F087	Read / Write	00	Bit[7:2] : Reserved Bit[1:0] : Display Start Position Y Coordinate – 1 bit[9:8] Display Start Position (X,Y) is for panning of the view port on a virtual display.
F088	Read / Write	0000 0000	LCD_LUT1 Bit[7:4] : for Gray level 3 Bit[3:0] : for Gray level 2
F089	Read / Write	0000 0000	LCD_LUT0 Bit[7:4] : for Gray level 1 Bit[3:0] : for Gray level 0
F08A	Read / Write	000 0000	Bit[7] : Reserved Bit[6:0] : Virtual Display Character count – 1 It supports horizontal virtual size up to 128 characters or 1024 pixels.
F08B	Read / Write	00 0000	Bit[7:6] : Reserved Bit[5:0] : WF count for STN panels 000000: WF pin toggles every frame 000001: WF pin toggles every 2 LP pulses 000010: WF pin toggles every 3 LP pulses 111111: WF pin toggles every 64 LP pulses
F08C	Read / Write	0000	Bit[7:4] : Reserved Bit[3:0] : Horizontal non-display period 0000: 2 characters (16 pixels) 0001: 3 characters (24 pixels) 1111: 17 characters (136 pixels)
F08D	Read / Write	0000	Bit[7:4] : Reserved Bit[3:0] : Vertical non-display period 0000: 1 line 0001: 2 lines 1111: 16 lines
F08E	Read / Write	0000 000	Bit[7:4] : Pixel Clock Divider 0000: 24 MHz (divided by 1) 0001: 12 MHz (divided by 2) 0010: 8 MHz (divided by 3) 0011: 6MHz (divided by 4) 1111: 1.5MHz (divided by 16) Bit[3] : Display Blank 0: Normal 1: Blank Bit[2] : Display Invert 0: Normal 1: Invert Bit[1] : LCD_ON Polarity 0: LCD_ON pin active low 1: LCD_ON pin active high Bit[0] : Reserved
F08F	Read / Write	000 0000	Bit[7] : Reserved Bit[6:0] : Number of frames to start – 1 Maximum 128 frames

Register (HEX)	R/W	Reset Value	Descriptions
F100	Read / Write	Bit[7:6] = 00 Bit[1:0] = 00	Bit[7] – Enable / Disable 0: Disable Sprite 1: Enable Sprite Bit[6] – Transparency 0: Transparency disable 1: Transparency enable When enabled: Sprite data = 00 becomes transparent and LCD background will be displayed instead. Bit[5:2] – Reserved Bit[1:0] – Sprite Modes Select 01: Sprite with 2 bit-per-pixel 00, 10, 11: Reserved
F102	Read / Write	0000 0000	Bit[7:0] - SP_LUT0L[7:0]
F103	Read / Write	0000 0000	Bit[7:0] - SP_LUT0H[7:0]
F104	Read / Write	0000 0000	Bit[7:0] - SP_LUT1L[7:0]
F105	Read / Write	0000 0000	Bit[7:0] - SP_LUT1H[7:0]
F106	Read / Write	0000 0000	Bit[7:0] - SP_LUT2L[7:0]
F107	Read / Write	0000 0000	Bit[7:0] - SP_LUT2H[7:0]
F108	Read / Write	0000 0000	Bit[7:0] - SP_LUT3L[7:0]
F109	Read / Write	0000 0000	Bit[7:0] - SP_LUT3H[7:0]
F10A	Read / Write	0000 0000	Bit[7:0] – Sprite Horizontal Pixel Count – 1 Maximum 256 pixels
F10B	Read / Write	0000 0000	Bit[7:0] – Sprite Vertical Line Count – 1 Maximum 256 lines
F10C	Read / Write	0000 0000	Bit[7:0] – Sprite Horizontal Start Position bit[7:0]
F10D	Read / Write	00	Bit[7:2] – Reserved Bit[1:0] - Sprite Horizontal Start Position bit[9:8] Sprite Horizontal Start Position bit[9:0] is measured in pixels and counted from left to right of the edge of the panel display (i.e. not virtual display).
F10E	Read / Write	0000 0000	Bit[7:0] – Sprite Vertical Start Position bit[7:0]
F10F	Read / Write	0	Bit[7:1] – Reserved Bit[0] - Sprite Vertical Start Position bit[8] Sprite Vertical Start Position bit[8:0] is measured in lines and counted from top to bottom of the edge of the panel display (i.e. not virtual display).
F142	Write Only	0000 0000	Bit[7:0] – Sprite / overlay storage starting address bit[7:0]
F143	Write Only	0000 0000	Bit[7:0] – Sprite / overlay storage starting address bit[15:8]
F144	Write Only	0000 0000	Bit[7:2] – Reserved Bit[1:0] – Sprite / overlay storage starting address bit[17:16] This is the starting address to put the sprite/overlay image

Register (HEX)	R/W	Reset Value	Descriptions
F500	Read / Write	Bit[7:4] = 1110 Bit[3:0] = 1110	CS0 Configuration Port – Pulse Width <u>Bit[7:4]</u> : Write Cycle Pulse Width 0000: 1 memory clock (24 MHz -> 41.6ns) 0001: 2 memory clocks 1110:15 memory clocks 1111: Reserved <u>Bit[3:0]</u> : Read Cycle Pulse Width 0000: 1 memory clock (24 MHz -> 41.6ns) 0001: 2 memory clocks 1110:15 memory clocks 1111: Reserved
F501	Read / Write	0000 0000	CS0 Configuration Port – Control <u>Bit[7]</u> : Enable bit 0:Disable CS0 1:Enable CS0 <u>Bit[6]</u> : Memory data bus width 0: 8-bit memory data bus width 1: 16-bit memory data bus width <u>Bit[5]</u> : 16-bit SRAM option 0:two 8-bit SRAMs 1:one 16-bit SRAM <u>Bit[4]</u> : Reserved <u>Bit[3]</u> : CS0 assertion time relative to address assertion. 0:CS0 and address assert at the same time 1:CS0 lags address by 1 memory clock. <u>Bit[2]</u> : CS0 Negation Timing 0:CS0 and Address negate at the same time 1:CS0 leads Address by 1 memory clock in write access. <u>Bit[1]</u> : Write Enable Assertion Time 0: Write Enable and Address Assert at the same time. 1: Write Enable lags Address by 1 memory clock. <u>Bit[0]</u> : Write Enable Negation Time 0: Write Enable and Address negate at the same time. 1: Write Enable leads Address by 1 memory clock.
F504	Read / Write	Bit[3:0] = 1110	CS1 Configuration Port – Pulse Width <u>Bit[7:4]</u> : Reserved <u>Bit[3:0]</u> : Read Cycle Pulse Width 0000: 1 memory clock (24 MHz -> 41.6ns) 0001: 2 memory clocks 0011: 3 memory clocks 1101:14 memory clocks 1110:15 memory clocks 1111: Reserved
F505	Read / Write	0000 0000	CS1 Configuration Port – Control <u>Bit[7]</u> : Enable bit 0:Disable CS1 1:Enable CS1 <u>Bit[6]</u> : Memory data bus width 0: 8-bit memory data bus width 1: 16-bit memory data bus width <u>Bit[5]</u> : Reserved <u>Bit[4]</u> : Reserved <u>Bit[3]</u> : CS1 assertion time relative to address assertion. 0:CS1 and Address assert at the same time 1:CS1 lags Address by 1 memory clock. <u>Bit[2]</u> : CS1 Negation Timing 0:CS1 and Address negate at the same time 1:CS1 leads Address by 1 memory clock in write access. <u>Bit[1:0]</u> : Reserved
F6C4	Read / Write	Bit[5:0] = 11 0011	Set Memory Clock Divide <u>Bit[7:6]</u> = Reserved <u>Bit[5:0]</u> = 010000 to set 24MHz memory clock for proper operations

5. Design and Handling Precaution

1. The LCD panel is made by glass. Any mechanical shock (eg. dropping from high place) will damage the LCD module.
2. Do not add excessive force on the surface of the display, which may cause the Display color change abnormally.
3. The polarizer on the LCD is easily get scratched. If possible, do not remove the LCD protective film until the last step of installation.
4. Never attempt to disassemble or rework the LCD module.
5. Only Clean the LCD with Isopropyl Alcohol or Ethyl Alcohol. Other solvents (eg. water) may damage the LCD.
6. When mounting the LCD module, make sure that it is free from twisting, warping and distortion.
7. Ensure to provide enough space (with cushion) between case and LCD panel to prevent external force adding on it, or it may cause damage to the LCD or degrade the display result.
8. Only hold the LCD module by its side. Never hold LCD module by add force on the heat seal or TAB.
9. Never add force to component of the LCD module. It may cause invisible damage or degrade of the reliability.
10. LCD module could be easily damaged by static electricity. Be careful to maintain an optimum anti-static work environment to protect the LCD module.
11. When peeling off the protective film from LCD, static charge may cause abnormal display pattern. It is normal and will resume to normal in a short while.
12. Take care and prevent get hurt by the LCD panel sharp edge.
13. Never operate the LCD module exceed the absolute maximum ratings.
14. Keep the signal line as short as possible to prevent noisy signal applying to LCD module.
15. Never apply signal to the LCD module without power supply.
16. IC chip (eg. TAB or COG) is sensitive to the light. Strong lighting environment could possibly cause malfunction. Light sealing structure casing is recommend.
17. LCD module reliability may be reduced by temperature shock.
18. When storing the LCD module, avoid exposure to the direct sunlight, high humidity, high temperature or low temperature. They may damage or degrade the LCD module