



深圳市拓普微科技开发有限公司

SHENZHEN TOPWAY TECHNOLOGY CO.,LTD.

# LMT050DNCFWU-NCN

## LCD Module User Manual

Prepared by:  <b>Yang</b>  Date: 2012-11-15	Checked by:    Date:	Approved by:    Date:
---	----------------------------------	-----------------------------------

Rev.	Descriptions	Release Date
0.1	Preliminary	2012-11-15

**Table of Content**

<b>1. General Specification .....</b>	<b>3</b>
<b>2. Block Diagram.....</b>	<b>3</b>
<b>3. Terminal Functions.....</b>	<b>4</b>
3.1 Interface .....	4
<b>4. Absolute Maximum Ratings .....</b>	<b>5</b>
<b>5. Electrical Characteristics .....</b>	<b>5</b>
5.1 DC Characteristics (MCU terminal).....	5
<b>6. AC Characteristics.....</b>	<b>6</b>
6.1 TFT Controller Timing Characteristics .....	6
6.2 TFT Controller Reset Timing .....	7
6.3 TFT Timing.....	8
<b>7. Optical Characteristics.....</b>	<b>9</b>
<b>8. Precautions of using LCD Modules.....</b>	<b>11</b>

**1. General Specification**

Screen Size(Diagonal) :	5.0 inch
Resolution :	800(RGB) x 480
Signal Interface :	8 bit parallel interface
Color Depth :	65,535 color (16bit) *1
Pixel Pitch :	0.36 x 0.36 (mm)
Pixel Configuration :	RGB Stripe
Display Mode :	Transmissive / normal white
Surface Treatment :	Anti-Glare Treatment
Viewing Direction :	6 o'clock
Outline Dimension :	142.0 x 79.0 x 6.9 (mm) (see attached drawing for details)
Active Area :	108 x 64.8 (mm)
Backlight :	2x7 LEDs
Operating Temperature :	-20 ~ +70°C
Storage Temperature :	-30 ~ +80°C

Note:

\*1 Color tune may slightly changed by temperature and driving voltage.

**2. Block Diagram**

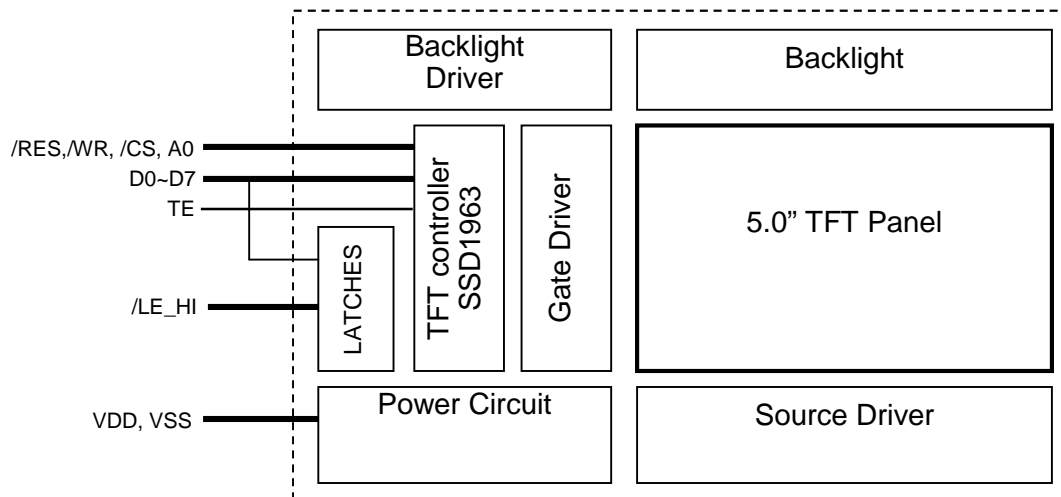

Note:

LATCHES on board expend the host 8bit data for SSD1963 16bit Interface.

### 3. Terminal Functions

#### 3.1 Interface

No.	Pin Name	I/O	Descriptions
1	VSS	P	Power Supply GND (0V)
2			
3	VDD	P	Positive Power Supply (5.0V)
4			
5	A0	I	Register Select A0=0, command A0=1, data or parameter
6	/CS	I	Chip Select signal
7	/RES	I	Reset signal, /RES=1, normal /RES=0, reset execute
8	D0(D8)	I	8bit Data bus
:	:		
15	D7(D15)		
16	TE	O	Tear Signal (*1)
17	NC	--	No Connection
18	/WR	I	Write signal
19	VSS	P	Power Supply GND (0V)
20	/LE_HI	I	LATCH the high byte data; /LE_HI=1, transparent; /LE_HI=0, LATCHED
21	NC	--	No Connection
:			
26			

Note.

\*1. Tear signal may leave open when not use

## 4. Absolute Maximum Ratings

Items	Symbol	Min.	Max.	Unit	Condition
Supply Voltage	V <sub>DD</sub>	-0.3	+6.0	V	GND = 0V
Operating Temperature	T <sub>OP</sub>	-20	+70	°C	No Condensation
Storage Temperature	T <sub>ST</sub>	-30	+80	°C	No Condensation

**Cautions:**

Any Stresses exceeding the Absolute Maximum Ratings may cause substantial damage to the device. Functional operation of this device at other conditions beyond those listed in the specification is not implied and prolonged exposure to extreme conditions may affect device reliability.

## 5. Electrical Characteristics

### 5.1 DC Characteristics (MCU terminal)

GND=0V, V<sub>DD</sub> =5.0V, T<sub>OP</sub> =25°C

Items	Symbol	MIN.	TYP.	MAX.	Unit	Applicable Pin
Operating Voltage	VDD	4.8	5.0	5.5	V	VDD
Input High Voltage	V <sub>IH</sub>	3.0	-	3.6	V	Input pins
Input Low Voltage	V <sub>IL</sub>	GND	-	0.3	V	Input pins
Output Signal Low Voltage	V <sub>OL</sub>	-	-	GND+0.4	V	
Output Signal High Voltage	V <sub>OH</sub>	3.3	-	-	V	
Operating Current (*1)	I <sub>DD</sub>	-	260	-	mA	60%PWM
			390			100%PWM

**Note.**

- \*1. For different LCM, the value may have a bit of difference.
- \*2. To test the current dissipation, use "all Black Pattern".

## 6. AC Characteristics

### 6.1 TFT Controller Timing Characteristics

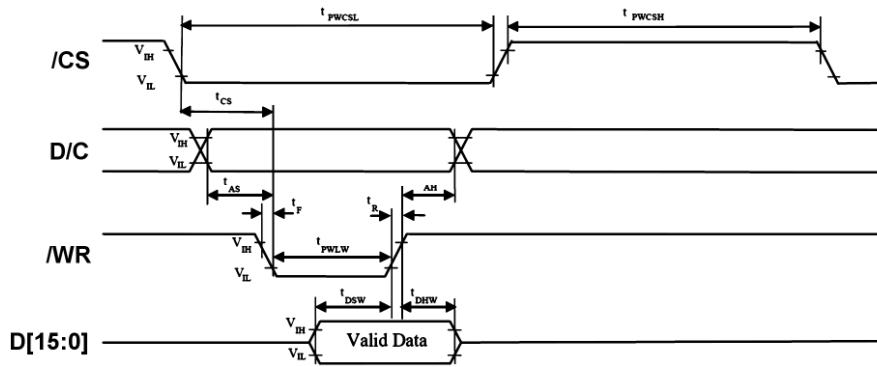

8080 Mode Write Timing

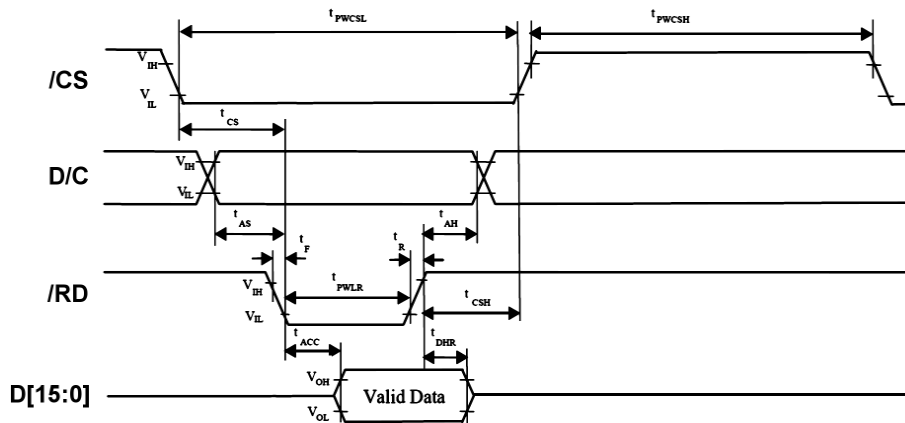

8080 Mode Read Timing

$V_{SS}=0V, V_{DD}=5.0V, T_{OP}=25^{\circ}C$

Item	Symbol	MIN.	TYP.	MAX.	Unit
System Clock Period(*1)	$t_{MCLK}$	$1/t_{MCLK}$	-	-	ns
Control Pulse High Width Write Read	$t_{PWCSL}$	16	$1.5*t_{MCLK}$	-	ns
		38	$1.3*t_{MCLK}$	-	ns
Control Pulse Low Width Write (next write cycle) Write (next read cycle) Read	$t_{PWCSH}$	16	$1.5*t_{MCLK}$	-	ns
		100	$9*t_{MCLK}$	-	ns
		100	$9*t_{MCLK}$	-	ns
Address Setup Time	$t_{AS}$	1.3	-	-	ns
Address Hold Time	$t_{AH}$	2.5	-	-	ns
Write Data Setup Time	$t_{DSW}$	5	-	-	ns
Write Data Hold Time	$t_{DHW}$	1.3	-	-	ns
Write Low Time	$t_{PWLW}$	15	-	-	ns
Read Data Hold Time	$t_{DHR}$	1.3	-	-	ns
Access Time	$t_{ACC}$	40	-	-	ns
Read Low Time	$t_{PWL R}$	45	-	-	ns
Rise Time	$t_R$	-	-	0.4	ns
Fall Time	$t_F$	-	-	0.4	ns
Chip select setup time	$t_{CS}$	2.5	-	-	ns
Chip select hold time to read signal	$t_{CSH}$	4	-	-	ns

Note:

\*1.  $t_{MCLK}$  is the System Clock Period, which may config by internal PLL setting

\*2. This Module is driving by 10MHz Xtal, and clock up by enabling the SSD1963 internal PLL

\*3. Suggested PLL clock setting is 200MHz

**6.2 TFT Controller Reset Timing**

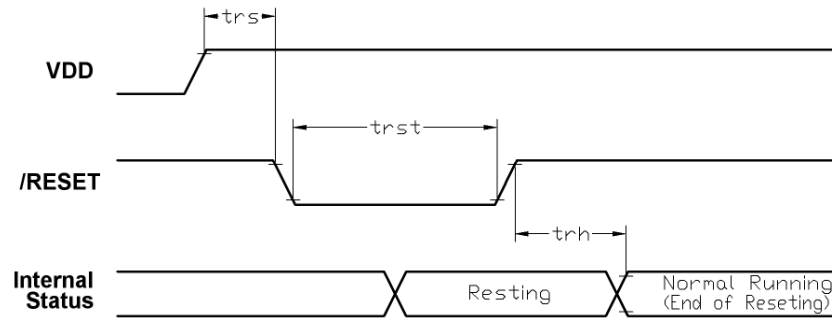

$V_{SS}=0V, V_{DD}=3.3V, T_{OP}=25^{\circ}C$

Item	Symbol	MIN.	TYP.	MAX.	Unit
Reset setup time	$tr_s$	2	-	-	ms
Reset pulse	$tr_{st}$	0.2	-	-	ms
Reset hold time	$tr_h$	2	-	-	ms

**6.3 TFT Timing**

Item	Symbol	MIN.	TYP.	MAX.	Unit	Remark
Horizontal Display Area	thd	800			DCLK	
CLKIN Frequency	fclk	-	30	50	MHz	
One Horizontal Line	th	889	928	1143	CLKIN	
HSD pulse width	thpw	1	48	255	CLKIN	
HSD Blanking	thb	88			CLKIN	
HSD Front Porch	thfp	1	40	255	CLKIN	
Vertical Display Area	tvd	480			TH	
VSD period time	tv	513	525	767	TH	
VSD pulse width	tvpw	3	3	255	TH	
VSD Blanking	tvb	32			TH	
VSD Front Porch	tvfp	1	13	255	TH	

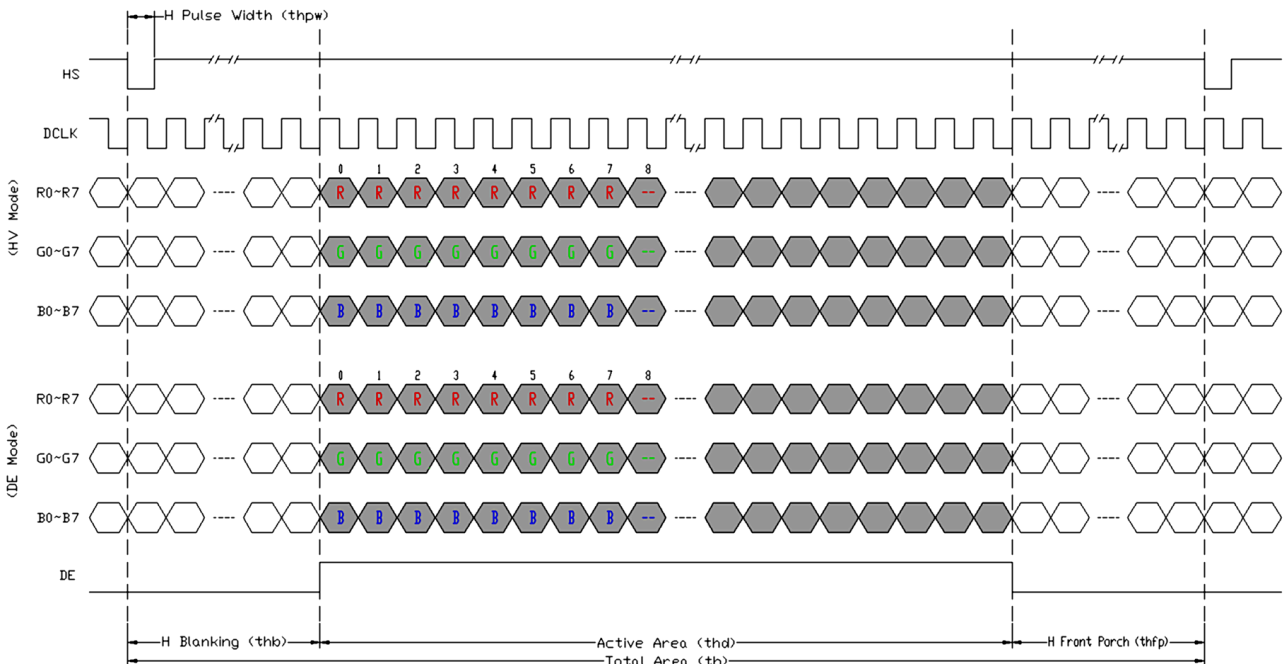

**Horizontal timing diagram**

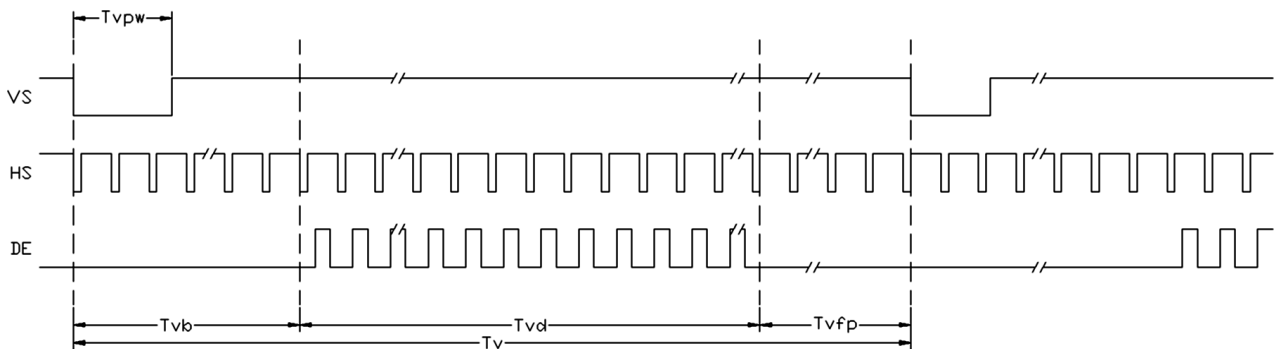

**Vertical timing diagram**



**7. Optical Characteristics**

Item	Symbol	Condition	MIN.	TYP.	MAX.	UNIT	Note.
Viewing angle	$\theta_T$	(CR $\geq$ 10)	40	50	-	degree	Note 2
	$\theta_B$		60	70	-		
	$\theta_L$		60	70	-		
	$\theta_R$		60	70	-		
Contrast ratio	CR	$\theta=0^\circ$	500	600	-	-	Note 1,3
Response Time	$T_{on}$	25°C	-	20	30	msec	Note 1,4
	$T_{off}$		-	-	-	msec	
Chromaticity	White	Backlight is on	X	0.260	0.310	0.360	Note 1,5
			Y	0.280	0.330	0.380	
	Red		X	0.540	0.590	0.640	
			Y	0.300	0.350	0.400	
	Green		X	0.298	0.348	0.398	
			Y	0.520	0.570	0.620	
	Blue		X	0.095	0.145	0.195	
			Y	0.060	0.110	0.160	
Luminance	L		-	135	-	cd/m <sup>2</sup>	Note 1,6
NTSC			-	50		%	Note 5
Luminance uniformity	U		75	80	-	%	Note 1,7

Test Conditions:

1. IF= 160 mA, VF=9.6V, and the ambient temperature is 25. °C
2. The test systems refer to Note 1 and Note 2.

Note 1:  
 The data are measured after LEDs are turned on for 5 minutes. LCM displays full white. The brightness is the average value of 9 measured spots. Measurement equipment SR-3A (1°)  
 Measuring condition:  
 - Measuring surroundings: Dark room  
 - Measuring temperature: Ta=25°C.  
 - Adjust operating voltage to get optimum contrast at the center of the display.

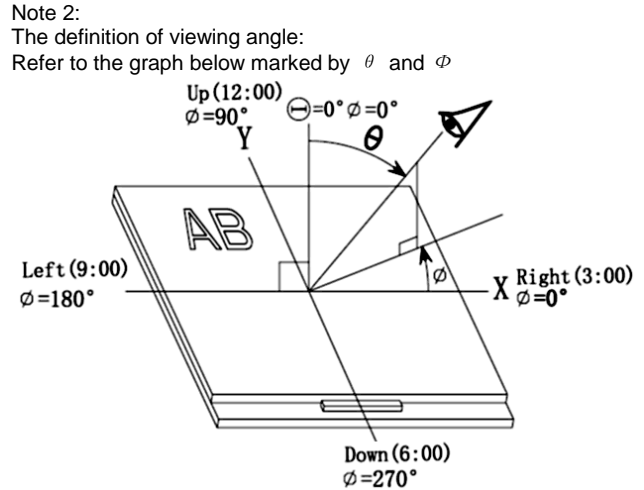

Note 3:  
 The definition of contrast ratio (Test LCM using SR-3A (1°)):  

$$\text{Contrast Ratio (CR)} = \frac{\text{Luminance When LCD is at "White" state}}{\text{Luminance When LCD is at "Black" state}}$$
 (Contrast Ratio is measured in optimum common electrode voltage)

Note 4:  
 Definition of Response time. (Test LCD using BM-7A(2°)):  
 The output signals of photo detector are measured when the input signals are changed from "black" to "white"(falling time) and from "white" to "black"(rising time), respectively. The response time is defined as the time interval between the 10% and 90% of amplitudes. Refer to figure as below.

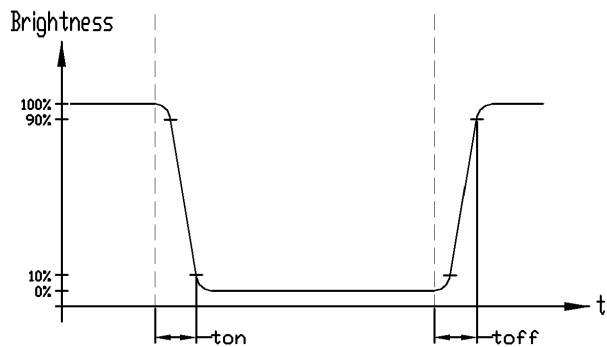

Note 5:  
 Definition of Color of CIE1931 Coordinate and NTSC Ratio.

Color gamut:  

$$S = \frac{\text{Area of RGB triangle}}{\text{Area of NTSC triangle}} \times 100\%$$

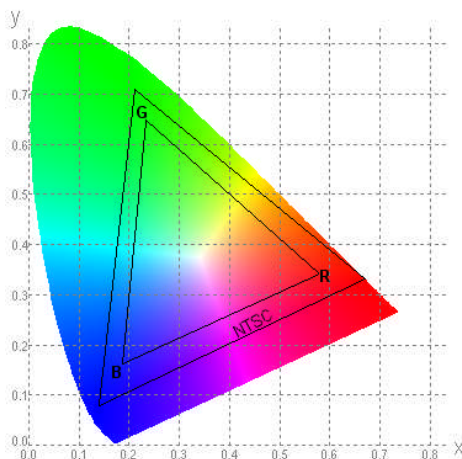

Note 6:  
 The luminance uniformity is calculated by using following formula.  

$$\Delta B_p = B_p (\text{Min.}) / B_p (\text{Max.}) \times 100 (\%)$$
  
 Bp (Max.) = Maximum brightness in 9 measured spots  
 Bp (Min.) = Minimum brightness in 9 measured spots.

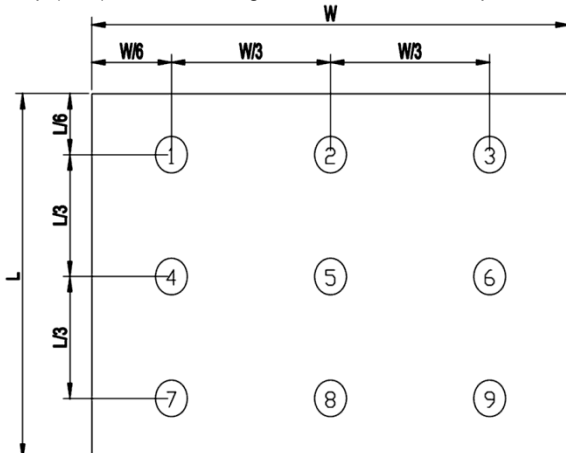

Note 7:  
 Measured the luminance of white state at center point

## 8. Precautions of using LCD Modules

### Mounting

- Mounting must use holes arranged in four corners or four sides.
- The mounting structure so provide even force on to LCD module. Uneven force (ex. Twisted stress) should not applied to the module. And the case on which a module is mounted should have sufficient strength so that external force is not transmitted directly to the module.
- It is suggested to attach a transparent protective plate to the surface in order to protect the polarizer. It should have sufficient strength in order to the resist external force.
- The housing should adopt radiation structure to satisfy the temperature specification.
- Acetic acid type and chlorine type materials for the cover case are not desirable because the former generates corrosive gas of attacking the polarizer at high temperature and the latter causes circuit break by electro-chemical reaction.
- Do not touch, push or rub the exposed polarizers with glass, tweezers or anything harder than HB pencil lead. Never rub with dust clothes with chemical treatment. Do not touch the surface of polarizer for bare hand or greasy cloth.(Some cosmetics deteriorate the polarizer.)
- When the surface becomes dusty, please wipe gently with absorbent cotton or other soft materials like chamois soaks with petroleum benzine. Normal-hexane is recommended for cleaning the adhesives used to attach front / rear polarizers. Do not use acetone, toluene and alcohol because they cause chemical damage to the polarizer.
- Wipe off saliva or water drops as soon as possible. Their long time contact with polarizer

### Operating

- The spike noise causes the mis-operation of circuits. It should be within the  $\pm 200\text{mV}$  level (Over and under shoot voltage)
- Response time depends on the temperature.(In lower temperature, it becomes longer.)
- Brightness depends on the temperature. (In lower temperature, it becomes lower.) And in lower temperature, response time(required time that brightness is stable after turned on) becomes longer.
- Be careful for condensation at sudden temperature change. Condensation makes damage to polarizer or electrical contacted parts. And after fading condensation, smear or spot will occur.
- When fixed patterns are displayed for a long time, remnant image is likely to occur.
- Module has high frequency circuits. Sufficient suppression to the electromagnetic interference shall be done by system manufacturers. Grounding and shielding methods may be important to minimized the interference

### Electrostatic Discharge Control

Since a module is composed of electronic circuits, it is not strong to electrostatic discharge. Make certain that treatment persons are connected to ground through wrist band etc. And don't touch interface pin directly.

### Strong Light Exposure

Strong light exposure causes degradation of polarizer and color filter.

### Storage

When storing modules as spares for a long time, the following precautions are necessary.

- Store them in a dark place. Do not expose the module to sunlight or fluorescent light. Keep the temperature between  $5^{\circ}\text{C}$  and  $35^{\circ}\text{C}$  at normal humidity.
- The polarizer surface should not come in contact with any other object. It is recommended that they be stored in the container in which they were shipped.

### Protection Film

- When the protection film is peeled off, static electricity is generated between the film and polarizer. This should be peeled off slowly and carefully by people who are electrically grounded and with well ion-blown equipment or in such a condition, etc.
- The protection film is attached to the polarizer with a small amount of glue. If some stress is applied to rub the protection film against the polarizer during the time you peel off the film, the glue is apt to be main on the polarizer. Please carefully peel off the protection film without rubbing it against the polarizer.
- When the module with protection film attached is stored for a long time, sometimes there remains a very small amount of glue still on the polarizer after the protection film is peeled off.
- You can remove the glue easily. When the glue remains on the polarizer surface or its vestige is recognized, please wipe them off with absorbent cotton waste or other soft material like chamois soaked with normal-hexane.

### Transportation

The LCD modules should be no falling and violent shocking during transportation, and also should avoid excessive press, water, damp and sunshine.