

# LMT057DNAFWU

## LCD Module User Manual

Shenzhen TOPWAY Technology Co., Ltd.

Rev.	Descriptions	Release Date
0.1	Preliminary New release	2005-09-13

**Table of Content**

<b>1. APPLICATIONS .....</b>	<b>3</b>
<b>2. General Specification .....</b>	<b>3</b>
<b>3. Block Diagram.....</b>	<b>3</b>
<b>4. Terminal Function (Input Terminal) .....</b>	<b>4</b>
<b>5. Absolute Maximum Ratings.....</b>	<b>5</b>
<b>6. Electrical Characteristics .....</b>	<b>6</b>
6.1 DC Characteristics .....	6
6.2 LED Backlight Circuit Characteristics.....	6
6.3 Power On Sequence (Voltage Source).....	6
<b>7. AC Characteristics.....</b>	<b>7</b>
7.1 Timing Conditions .....	7
<b>8. Optical Characteristics.....</b>	<b>8</b>
<b>9. Precautions of using LCD Modules .....</b>	<b>9</b>
<b>10. Appendix A &lt;Inspection items and criteria for appearance defect&gt;.....</b>	<b>10</b>

### 1. APPLICATIONS

This Module is designed for potable DVD, GPS car TV & PMP(portable multimedia player) application which require high quality flat panel displays. It is also a good substitute for many outmoded CSTN module in the industrial application.

This product is composed of a TFT-LCD panel, driver ICs, FPC and LED backlight unit.

### 2. General Specification

Signal Interface :	Digital 24-bits RGB
Display Technology :	a-Si TFT active matrix
Display Mode :	TN Type Full Color / Transmissive / Normal White
Screen Size(Diagonal) :	5.7"
Outline Dimension :	126.08 x 101.54 x 4.74 (mm) (see attached drawing for details)
Active Area :	115.2 x 86.4 (mm)
Number of dots :	320 x 3 (RGB) x 240
Dot Pitch :	0.12 x 0.63 (mm)
Pixel Configuration :	RGB Stripe
Backlight :	LED
Surface Treatment :	Anti-Glare Treatment
Viewing Direction :	12 o'clock
Operating Temperature :	-20 ~ +70°C
Storage Temperature :	-30 ~ +80°C

### 3. Block Diagram

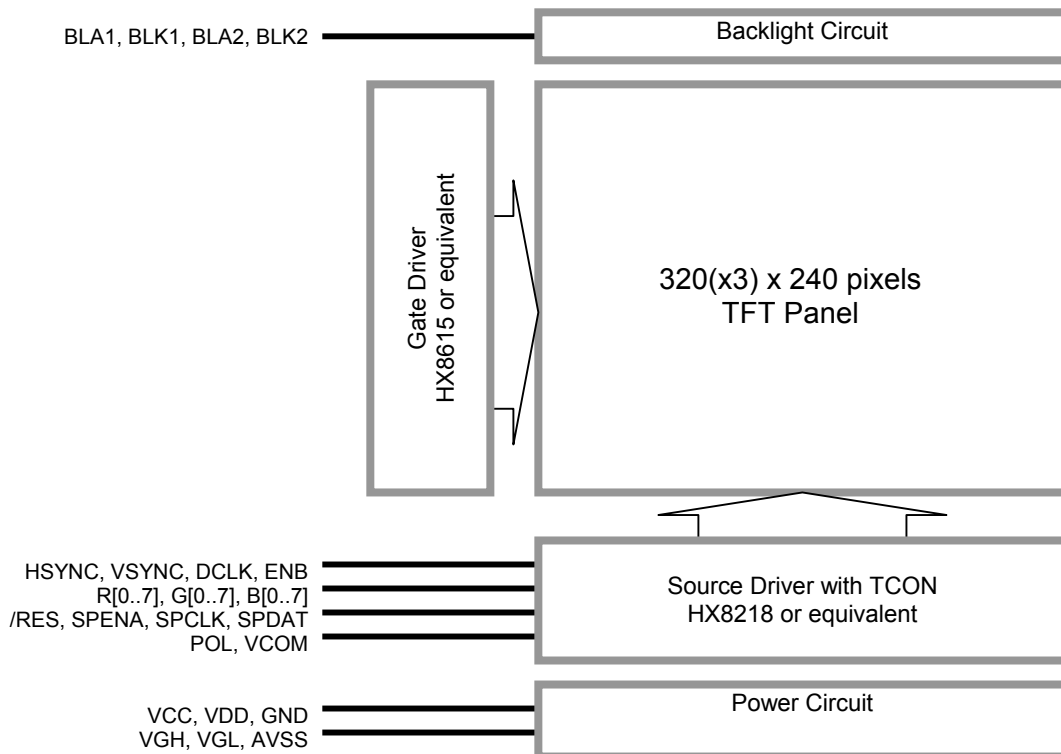

**4. Terminal Function (Input Terminal)**

Pin No.	Pin Name	IO	Descriptions
1	NC	-	No connection
:	:		
6	NC		
7	POL	Output	Polarity Signal for VCOM circuit
8	/RES	Input	Hardware Reset
9	SPENA	Input	Serial port Enable (*3)
10	SPCLK	Input	Serial port clock (*3)
11	SPDAT	Input	Serial port Data input
12	B0	Input	8bit Data for Blue
:	:		
19	B7		
20	G0	Input	8bit Data for Green
:	:		
27	G7		
28	R0	Input	8bit Data for Red
:	:		
35	R7		
36	HSYNC	Input	Horizontal Sync Input
37	VSYNC	Input	Vertical Sync Input
38	DCLK	Input	Clock Signal for RGB data Latching at the rising edge
39	VDD	Power	Analog Power Supply
40	VDD		
41	VCC	Power	Digital Power Supply
42	VCC		
43	NC	-	No connection
44	NC		
45	VGL	Power	Gate OFF power supply
46	NC	-	No connection
47	VGH	Power	Power Supply LCD Drive
48	NC	-	No connection
:	:		
50	NC		
51	VCOM	Input	Polarity Driving Input (*2)
52	ENB	Input	Data Enable
53	GND	Power	Power GND (0V)
54	AVSS	Power	Power GND (0V)

Note:

- \*1 The polarity of VCOM signal should be generated from POL
- \*2 For digital RGB input data format, both SYNC mode and DE+SYNC mode are supported.  
If ENB signal is fixed low, SYNC mode is used. Otherwise, DE+SYNC is used.
- \*3 SPENA & SPCLK always pull high

**5. Absolute Maximum Ratings**

$V_{SS}=0V, T_{OP}=25^{\circ}C$

Items	Symbol	Min.	Max.	Unit	Condition
Analog Supply Voltage for Source Driver	$AV_{DD}$	-0.3	+7.0	V	$V_{SS} = 0V$
Digital Supply Voltage for Source Driver	$V_{DD}$	-0.3	+7.0	V	$V_{SS} = 0V$
Positive Supply Voltage for Gate Driver	$V_{GH}$	-0.3	+32.0	V	$V_{SS} = 0V$
Negative Supply Voltage for Gate Driver	$V_{GL}$	-22.0	+0.3	V	$V_{SS} = 0V$
Gate Drive	$V_{GH}-V_{GL}$	-0.3	+45.0	V	$V_{SS} = 0V$
Digital Input Voltage	$V_{IN}$	-0.3	$V_{DD}+0.3$	V	$V_{SS} = 0V$
Operating Temperature	$T_{OP}$	-20	70	$^{\circ}C$	No Condensation
Storage Temperature	$T_{ST}$	-30	80	$^{\circ}C$	No Condensation

Note:

- \*1. This rating applies to all parts of the module and should not be exceeded.
- \*2. Maximum wet-bulb temperature is 70 . Condensation of dew must be avoided as electrical current leaks will occur, causing a degradation of performance specifications.
- \*3. The operating temperature only guarantees operation of the circuit. The contrast, response speed, and the other specification related to electro-optical display quality is determined at the room temperature,  $T_a=25$ .
- \*4. Ambient temperature when the backlight is lit (reference value)
- \*5. Any Stresses exceeding the Absolute Maximum Ratings may cause substantial damage to the device. Functional operation of this device at other conditions beyond those listed in the specification is not implied and prolonged exposure to extreme conditions may affect device reliability.

## 6. Electrical Characteristics

### 6.1 DC Characteristics

$V_{SS}=0V, V_{DD}=5.0V, T_{OP}=25^{\circ}C$

Items	Symbol	MIN.	TYP.	MAX.	Unit
Digital Supply Voltage	$V_{CC}$	3.0	3.3	3.6	V
Digital Operating Current	$I_{CC}$	-	0.02	-	V
Analog Supply Voltage	$V_{DD}$	3.8	5.0	5.5	V
Gate on Supply Voltage	$V_{GH}$	-	15	-	V
Gate off Supply Voltage	$V_{GL}$	-	-10	-	V
VCOM High Voltage(*1)	$V_{COMH}$	2.5	-	4.0	V
VCOM Low Voltage(*1)	$V_{COML}$	-2.0	-	0	V
Frame Frequency	$F_{FRAME}$	-	60	200	Hz

Note:

\*1. VCOMH& VCOML is for adjusting the color with gamma data

### 6.2 LED Backlight Circuit Characteristics

$V_{BLK1}=V_{BLK2}= 0V, I_{f_{BLA1}}+I_{f_{BLA2}}=60mA, T_{OP}=25^{\circ}C$

Items	Symbol	MIN.	TYP.	MAX.	Unit	Note
Forward Voltage	$V_{f_{BLA}}$	-	12.4	-	V	BLA1, BLA2
Forward Current	$I_{f_{BLA}}$	-	-	100	mA	BLA1+BLA2
Life Time	-	-	20000	-	hr	
Uniformity	-	75	80	-	%	

Cautions:

Exceeding the recommended driving current could cause substantial damage to the backlight and shorten its lifetime.

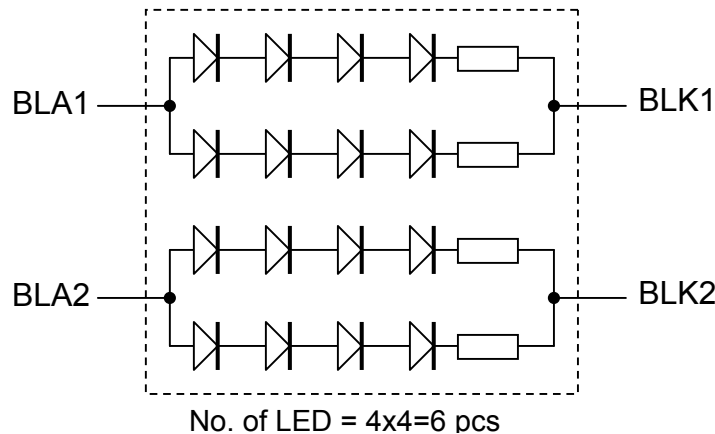

### 6.3 Power On Sequence (Voltage Source)

The LCD panel adopts high voltage driver ICs, so it could be damaged permanently if a wrong power on/off sequence is used. To prevent the LCD panel from damage due to latch up, the power ON/OFF sequence shown below must be follow:

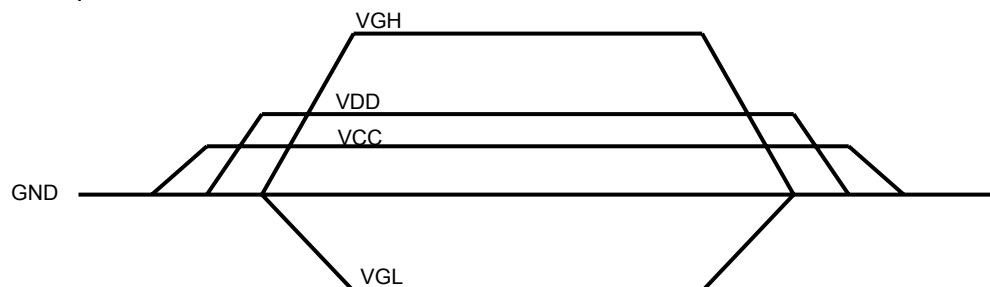

## 7. AC Characteristics

### 7.1 Timing Conditions

Item	Symbol	MIN.	TYP.	MAX.	Unit
DCLK period	Tosc	-	156	-	ns
Data Setup Time	Tsu	12	-	-	ns
Data Hold Time	Thd	12	-	-	ns
VSYNC Falling Time	Tvf	-	-	1500	ns
VSYNC Rising Time	Tvr	-	-	700	ns
HSYNC Falling Time	Tcf	-	-	300	ns
HSYNC Rising Time	Tcr	-	-	700	ns

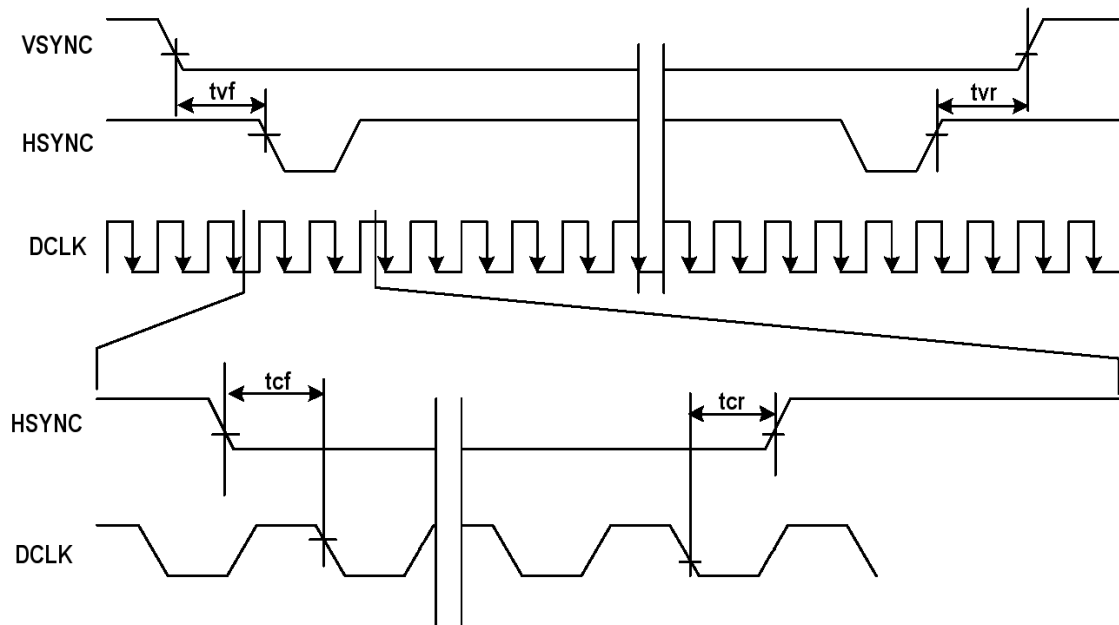

**HSYNC / VSYNC / DCLK Timing Diagram**

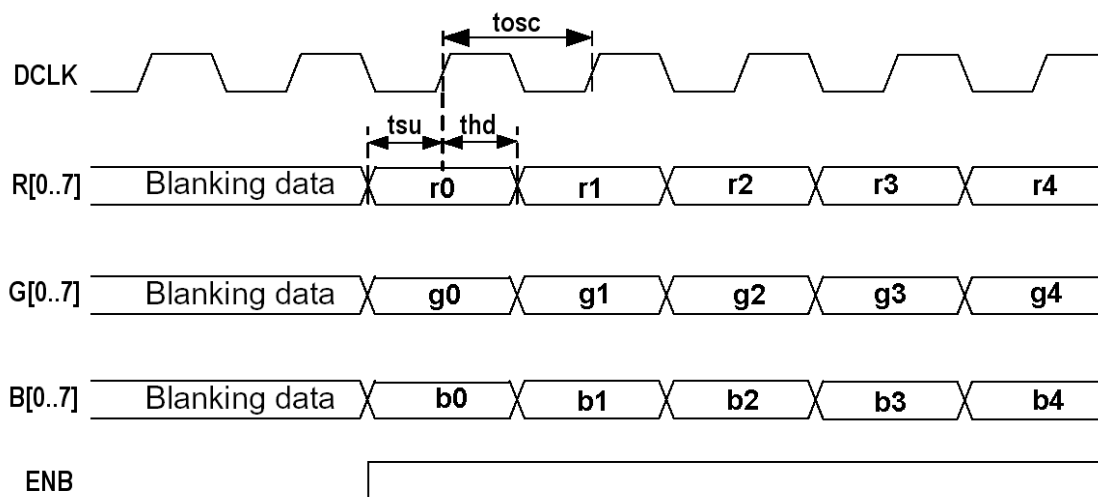

**RGB / DCLK / ENB Timing Diagram**

## 8. Optical Characteristics

Light source: C light, using CMO TN LC + Polarizer reference only

Item	Symbol	MIN.	TYP.	MAX.	UNIT	Note.
Brightness	-	200	250	-	nit	
Transmittance	Tr		8.6	-	%	
Contrast Ratio	CR	150	250	-	-	(*1)
White Color Chromaticity(X)	W <sub>X</sub>	0.282	0.313	0.342	-	
White Color Chromaticity(Y)	W <sub>Y</sub>	0.299	0.338	0.359	-	
Response Time Rise	T <sub>R</sub>	-	15	30	ms	
Response Time Fall	T <sub>F</sub>	-	35	50	ms	
Viewing Angle(Φ=180°)	θ <sub>l</sub>	-	15	-	deg	CR≥10 (*2)
Viewing Angle(Φ=0°)	θ <sub>r</sub>	-	45	-	deg	CR≥10 (*2)
Viewing Angle(Φ=90°)	θ <sub>u</sub>	-	15	-	deg	CR≥10 (*2)
Viewing Angle(Φ=270°)	θ <sub>d</sub>	-	35	-	deg	CR≥10 (*2)
NTSC Ratio	S	-	50%	-	-	

Note:

**\*1. Definition of Contrast Ratio**

The contrast ratio could be calculate by the following expression:

$$\text{Contrast Ratio (CR)} = L_{63} / L_0$$

Where : L<sub>63</sub>=Luminance of gray level 63

L<sub>0</sub>=Luminance of gray level 0

CR=CR at middle point of the LCD panel.

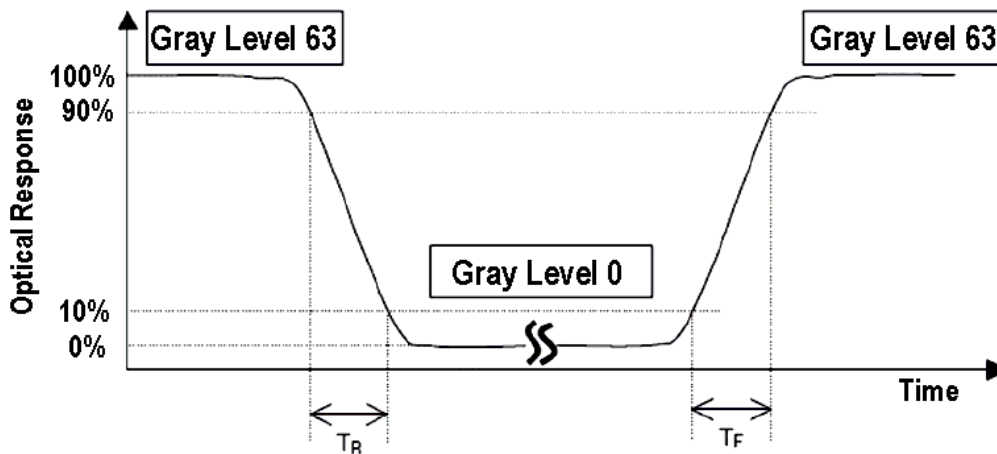

**\*2 Definition of Viewing Angle**

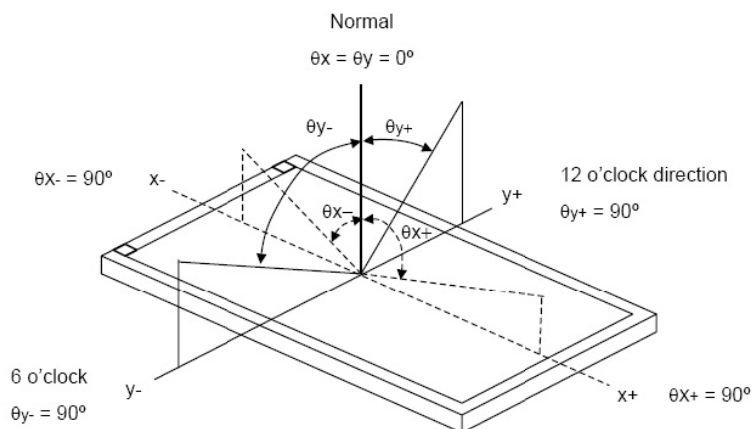



## 9. Precautions of using LCD Modules

### Mounting

- Mounting must use holes arranged in four corners or four sides.
- The mounting structure so provide even force on to LCD module. Uneven force (ex. Twisted stress) should not applied to the module. And the case on which a module is mounted should have sufficient strength so that external force is not transmitted directly to the module.
- It is suggested to attach a transparent protective plate to the surface in order to protect the polarizer. It should have sufficient strength in order to the resist external force.
- The housing should adopt radiation structure to satisfy the temperature specification.
- Acetic acid type and chlorine type materials for the cover case are not desirable because the former generates corrosive gas of attacking the polarizer at high temperature and the latter causes circuit break by electro-chemical reaction.
- Do not touch, push or rub the exposed polarizers with glass, tweezers or anything harder than HB pencil lead. Never rub with dust clothes with chemical treatment. Do not touch the surface of polarizer for bare hand or greasy cloth.(Some cosmetics deteriorate the polarizer.)
- When the surface becomes dusty, please wipe gently with absorbent cotton or other soft materials like chamois soaks with petroleum benzine. Normal-hexane is recommended for cleaning the adhesives used to attach front / rear polarizers. Do not use acetone, toluene and alcohol because they cause chemical damage to the polarizer.
- Wipe off saliva or water drops as soon as possible. Their long time contact with polarizer

### Operating

- The spike noise causes the mis-operation of circuits. It should be within the  $\pm 200\text{mV}$  level (Over and under shoot voltage)
- Response time depends on the temperature.(In lower temperature, it becomes longer.)
- Brightness depends on the temperature. (In lower temperature, it becomes lower.) And in lower temperature, response time(required time that brightness is stable after turned on) becomes longer.
- Be careful for condensation at sudden temperature change. Condensation makes damage to polarizer or electrical contacted parts. And after fading condensation, smear or spot will occur.
- When fixed patterns are displayed for a long time, remnant image is likely to occur.
- Module has high frequency circuits. Sufficient suppression to the electromagnetic interference shall be done by system manufacturers. Grounding and shielding methods may be important to minimized the interference

### Electrostatic Discharge Control

Since a module is composed of electronic circuits, it is not strong to electrostatic discharge. Make certain that treatment persons are connected to ground through wrist band etc. And don't touch interface pin directly.

### Strong Light Exposure

Strong light exposure causes degradation of polarizer and color filter.

### Storage

When storing modules as spares for a long time, the following precautions are necessary.

- Store them in a dark place. Do not expose the module to sunlight or fluorescent light. Keep the temperature between  $5^{\circ}\text{C}$  and  $35^{\circ}\text{C}$  at normal humidity.
- The polarizer surface should not come in contact with any other object. It is recommended that they be stored in the container in which they were shipped.

### Protection Film

- When the protection film is peeled off, static electricity is generated between the film and polarizer. This should be peeled off slowly and carefully by people who are electrically grounded and with well ion-blown equipment or in such a condition, etc.
- The protection film is attached to the polarizer with a small amount of glue. If some stress is applied to rub the protection film against the polarizer during the time you peel off the film, the glue is apt to be main on the polarizer. Please carefully peel off the protection film without rubbing it against the polarizer.
- When the module with protection film attached is stored for a long time, sometimes there remains a very small amount of glue still on the polarizer after the protection film is peeled off.
- You can remove the glue easily. When the glue remains on the polarizer surface or its vestige is recognized, please wipe them off with absorbent cotton waste or other soft material like chamois soaked with normal-hexane.

### Transportation

The LCD modules should be no falling and violent shocking during transportation, and also should avoid excessive press, water, damp and sunshine.

**10. Appendix A <Inspection items and criteria for appearance defect>**

Items	Criteria			
Open Segment or Common	Not permitted			
Short	Not permitted			
Wrong Viewing Angle	Not permitted			
Decliners	Not permitted			
Contrast Ration Uneven	According to the limit specimen			
Crosstalk	According to the limit specimen			
White spots	X>1 pixel	A-area	Not permitted	Max 6 spots allowed
		B-area	Max. 1 allowed	
	1/2 pixel<X≤1 pixel	A-area	Not permitted	
		B-area	Max. 2 allowed	
	X≤1/2 pixel	A-area	Max. 1 allowed	
		B-area	Max. 4 allowed	
Black Sport	X>1 pixel	A-area	Not permitted	
		B-area	Max. 2 allowed	
	X≤1/2 pixel	A-area	Max. 1 allowed	
		B-area	Max. 4 allowed	
Line Defect	Apparent vertical horizontal line defects are not permitted			

Note:

1. On Pixel include 3 dots (RedDot + GreenDot + BlueDot)
2. Definition of Panel "A-area" and "B-area"

