

Table of Content

1. Basic Specifications	3
1.1 Display Specifications	3
1.2 Mechanical Specifications	3
1.3 Block Diagram	3
1.4 Terminal Functions	4
2. Absolute Maximum Ratings	5
3. Electrical Characteristics	5
3.1 DC Characteristics	5
3.2 LED Backlight Circuit Characteristics	5
3.3 AC Characteristics	6
3.4 Reset Timing	6
4. Function Specifications	7
4.1 Adjusting the Display Contrast	7
4.2 Resetting the LCD module	7
4.3 Interfacing Setting	7
4.4 Display Pixel Map	7
4.5 Control Data and Command	8
4.6 Command Summary	8
5. Design and Handling Precaution	12

1. Basic Specifications

1.1 Display Specifications

- 1) LCD Display Mode : STN-Gray, Positive, Transflective
- 2) Display Color : Display Data = "1" : Dark Blue (*1)
: Display Data = "0" : Light Gray (*2)
- 3) Viewing Angle : 6H
- 4) Driving Method : 1/64 duty, 1/8.2 bias
- 5) Backlight : White LED backlight

Note:

*1. Color tone may slightly change by Temperature and Driving Condition.

*2. The Color is defined as the inactive / background color

1.2 Mechanical Specifications

- 1) Outline Dimension : 180.0 x 62.0 x 12.3 MAX.
see attached Outline Drawing for details

1.3 Block Diagram

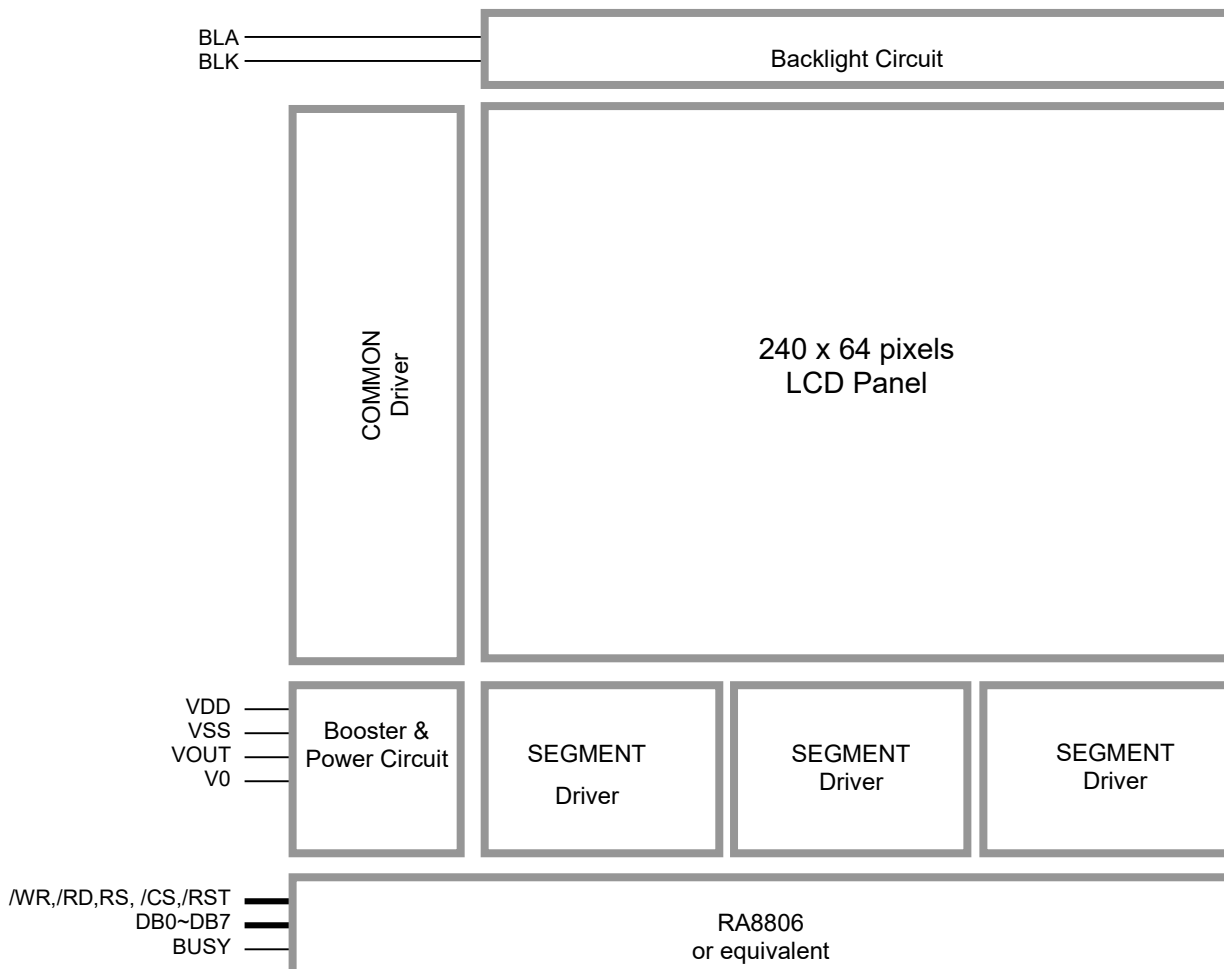

1.4 Terminal Functions

Pin No. K1	Pin Name	I/O	Descriptions
1	VOUT	Power	Power Booster Output for V0
2	V0	Input	LCD Contrast Reference Input
3	VSS	Power	0V Power Supply, GND
4	VDD	Power	Positive Power Supply
5	BUSY	Output	Indicate the RA8806 in busy state or not,could been used for MPU to get busy state by connecting it to IO port
6	NC	NC	No connection,leave open
7	/CS	Input	Chip Select Signal /CS=LOW: Data IO is enabled
8	RS	Input	Register Select RS=HIGH: write address of register and read status word RS=LOW: write & read data of register and DDRAM
9	/WR	Input	Write enable input, active LOW
10	/RD	Input	Read enable input, active LOW
11	DB0	I/O	8-bit bi-directional data bus
:	:		
18	DB7		
19	/RST	Input	Reset Signal: /RST = L, Reset the LCD Module /RST = H, Normal Running
20	NC	NC	No connection,leave open
21	BLA	Power	Positive Power Supply for LED backlight
22	BLK	Power	Negative Power Supply for LED backlight
23	BLA	Power	Positive Power Supply for LED backlight
24	BLK	Power	Negative Power Supply for LED backlight
25	BLA	Power	Positive Power Supply for LED backlight
26	BLK	Power	Negative Power Supply for LED backlight

note:

*1. The LCM Fixed to 80 mode by default ,could been changed to 68 mode by changing jumpers

2. Absolute Maximum Ratings

Items	Symbol	Min.	Max.	Unit	Condition
Supply Voltage	V_{DD}	0	+3.3	V	$V_{SS} = 0V$
Input Voltage	V_{IN}	$V_{SS}-0.3$	$V_{DD}+0.3$	V	$V_{SS} = 0V$
Operating Temperature	T_{OP}	-20	+70	°C	No Condensation
Storage Temperature	T_{ST}	-30	+80	°C	No Condensation

Cautions:

Any Stresses exceeding the Absolute Maximum Ratings may cause substantial damage to the device. Functional operation of this device at other conditions beyond those listed in the specification is not implied and prolonged exposure to extreme conditions may affect device reliability.

3. Electrical Characteristics

3.1 DC Characteristics

$V_{SS}=0V, V_{DD}=3.3V, T_{OP}=25^{\circ}C$

Items	Symbol	MIN.	TYP.	MAX.	Unit	Applicable Pin
Operating Voltage	V_{DD}	3.0	3.3	3.6	V	VDD
Input High Voltage	V_{IN}	0.8VDD	-	VDD	V	DB0~DB7, /WR, /RD, /CS, RS, /RST
Input Low Voltage	V_{IN}	VSS	-	0.1VDD	V	DB0~DB7, /WR, /RD, /CS, RS, /RST
LCD Contrast Reference Voltage	V_0	-	11.7	-	V	V0
Operating Current	I_{DD}	-	9.0	25	mA	VDD

3.2 LED Backlight Circuit Characteristics

$BLK=0V, I_{f_{BLA}}=102mA, T_{OP} = 25^{\circ}C$

Items	Symbol	MIN.	TYP.	MAX.	Unit	Applicable Pin
Forward Voltage	$V_{f_{BLA}}$	-	3.3	-	V	BLA
Forward Current	$I_{f_{BLA}}$	-	102	120	mA	BLA

Cautions:

Exceeding the recommended driving current could cause substantial damage to the backlight and shorten its lifetime.

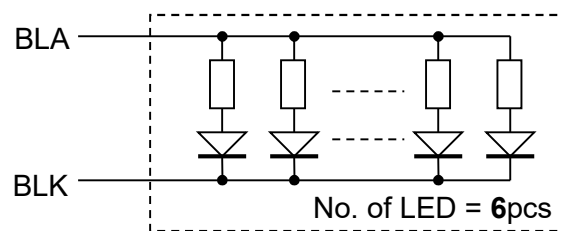

3.3 AC Characteristics

3.3.1 8080 Mode

$V_{SS}=0V, V_{DD}=3.3V, T_{OP}=25^{\circ}C$

Item	Symbol	MIN.	TYP.	MAX.	Unit
System Cycle Time (*2)	tcyc8	320	-	-	ns
Strobe Pulse Width	tcc8	63	-	-	ns
Address Setup Time	tas8	10	-	-	ns
Address Hold Time	tah8	25	-	-	ns
Data Setup Time	tds8	38	-	-	ns
Data Hold Time	tdh8	25	-	-	ns
Data Access Time	tacc8	-	-	25	ns
Output disable Time	toh8	-	-	13	ns

Note: *1. Input signal rise/fall time should be less than 20ns
 *2. System clock=6MHz
 *3. Bus timing is for one byte transaction only.
 For details, please refer to RA8806 datasheet.

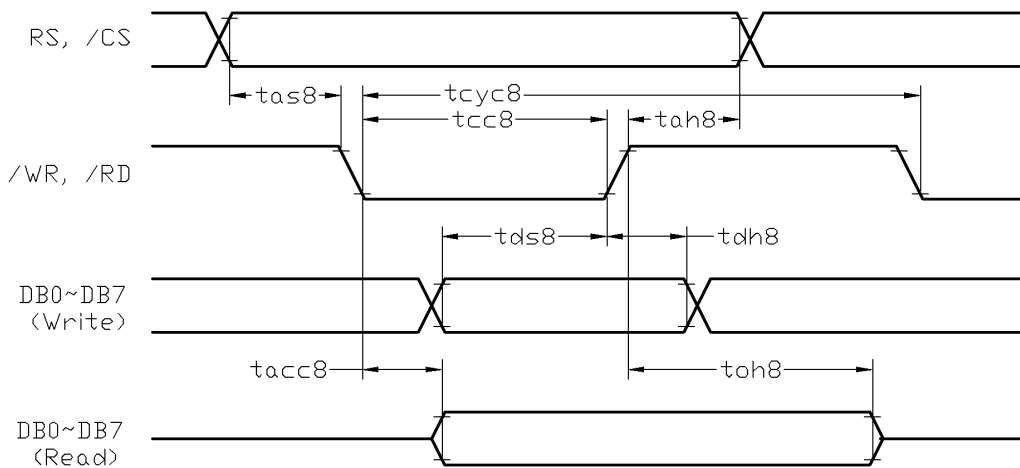

Bus Timing Diagram

3.4 Reset Timing

$V_{SS}=0V, V_{DD}=3.3V, T_{OP}=25^{\circ}C$

Item	Symbol	MIN.	TYP.	MAX.	Unit
Reset setup time	trs	1.3	-	-	ms
Reset hold time	trh	1.3	-	-	ms
Reset active time (*1)	trst	0.2	-	-	us

Note: *1. System clock=6MHz

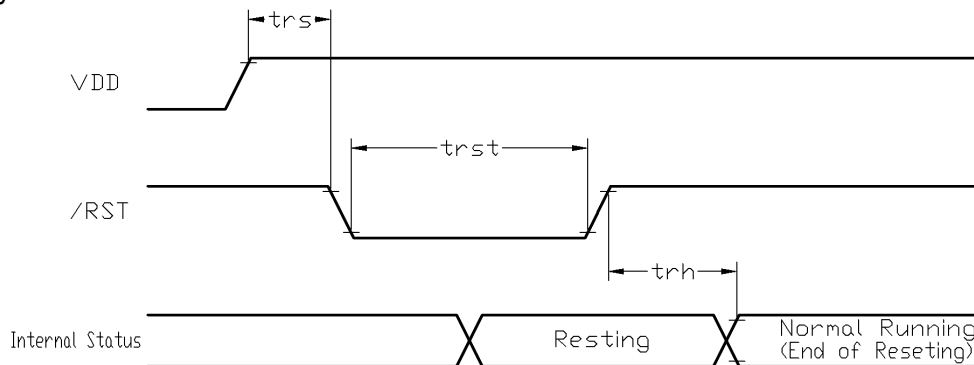

Reset Timing Diagram

4. Function Specifications

4.1 Adjusting the Display Contrast

A Variable-Resistor must be connected to the LCD module for providing a reference to V0. Adjusting the VR will result the change of LCD display contrast. The recommended value of VR is 25k to 50k

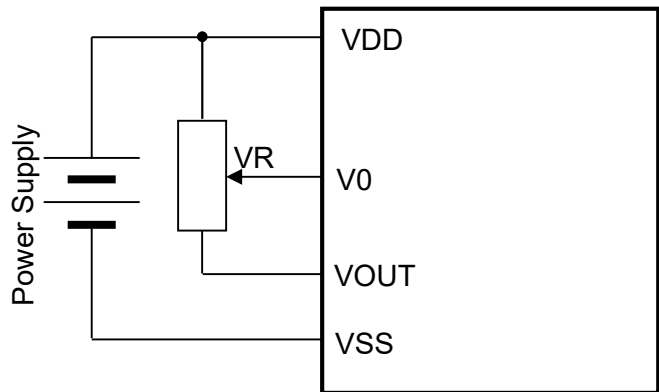

4.2 Resetting the LCD module

The LCD module should be initialized by hardware reset, using /RST terminal. While turning on the VDD and VSS power supply, maintain /RST terminal at LOW level. After the power supply stabilized, release the reset terminal (/RST=HIGH)

4.3 Interfacing Setting

Jumpers could be used to change bus interfacing family

Jumper				Function Discription
JP6	JP7	JP8	JP9	
open	close	close	open	8080 mode 8 bit selected <default>
open	open	close	close	6800 mode 8 bit selected
close	open	open	close	6800 mode 4 bit selected

4.4 Display Pixel Map

1,1 (D7)	2,1 (D6)	3,1 (D5)	4,1 (D4)	5,1 (D3)	---	---	236,1 (D4)	237,1 (D3)	238,1 (D2)	239,1 (D1)	240,1 (D0)
1,2 (D7)	2,2 (D6)	3,2 (D5)	4,2 (D4)	5,2 (D3)	---	---	236,2 (D4)	237,2 (D3)	238,2 (D2)	239,2 (D1)	240,2 (D0)
1,3 (D7)	2,3 (D6)	3,3 (D5)	4,3 (D4)	5,3 (D3)	---	---	236,3 (D4)	237,3 (D3)	238,3 (D2)	239,3 (D1)	240,3 (D0)
:	:	:	:	:	:	:	:	:	:	:	:
1, 62 (D7)	2, 62 (D6)	3, 62 (D5)	4, 62 (D4)	5, 62 (D3)	---	---	236,62 (D4)	237, 62 (D3)	238,262 (D2)	239, 62 (D1)	240,62 (D0)
1, 63 (D7)	2, 63 (D6)	3, 63 (D5)	4, 63 (D4)	5, 63 (D3)	---	---	236, 63 (D4)	237, 63 (D3)	238, 63 (D2)	239,263 (D1)	240,63 (D0)
1, 64 (D7)	2, 64 (D6)	3, 64 (D5)	4, 64 (D4)	5, 64 (D3)	---	---	236, 64 (D4)	237, 64 (D3)	238,264 (D2)	239, 64 (D1)	240,64 (D0)

Pixel mapping (Top View)

Note:

- *1. Based on the top view of the LCD module, the 1, 1 (x, y) pixel is the upper-left pixel; the 240, 64 (x, y) pixel is the lower-right pixel.
- *2. For the details of memory mapping please refer to RA8806 datasheet.

4.5 Control Data and Command

The LCD module setting is controlled by the internal Register Values. The Register Address should be addressed when RS=1 and Register Value should be issued when RS=0.

A full command sequence should be as follow.

Steps	/RD	/WR	RS	Data (DB0~ DB7)
1 st	1	0	1	Register Address
2 nd	1	0	0	Register Value

4.6 Command Summary

Note:

For details please refer to RA8806 datasheet.

Reg. Add	Reg. Name	R/W	D7	D6	D5	D4	D3	D2	D1	D0	Descriptions
--	STATUS	R	MBUSY	SBUSY	SLEEP	-	-	WAKE_STS	KS_STS	TP_STS	MBUSY: Memory Write Busy Flag 1=Busy when write font or clear RAM; 0=not busy SBUSY: Scan Busy Flag 1=Busy when driver scan logic is not idle; 0=not busy SLEEP: Sleep state 1= In Sleep mode; 0=In Normal mode WAKE_STS: Wakeup Status Bit Same as REG[0FH] Bit2 KS_STS: Key Status Bit Same as REG[0FH] Bit1 TP_STS: Tp Status Bit Same as REG[0FH] Bit0
00h	WLCR	R/W	PWR	LINER	SR	-	CG	DP	BK	DV	PWR : Power Mode 1=In Sleep Mode; 0=In Normal Mode LINER: linear Decode Mode 1=User-defined ROM mapping rule; 0=GIG5/GB ROM mapping rule SR : Software Reset 1=reset all register (except DDRAM); 0=normal operation CG : Display mode selection 1=Character Mode; 0=Graphic Mode DP : Display on off control 1=normal display; 0=display off BK : Full screen blinking control 1=blinking (blink time is set by REG 80H); 0=normal; DV : Full screen inverse control 1=Inverse Full Screen; 0=Normal
01h	MISC	R/W	NO_FLICKER	CKN	BUSY_LEV	INT_LEV	XCK_SEL1	XCK_SEL0	SDIR	CDIR	NO_FLICKER : Eliminating Flicker 1=enable, scan will auto-pending when busy; 0=disable CKN : Clock Output in pin CLK_OUT 1=The pin indicates SLEEP state of STATUS REG; 0=The pin output internal system clock BUSY_LEV : Busy Polarity(for "BUSY" pin) 1=Set Active High; 0=Set Active Low INT_LEV: Interrupt Polarity (for "INT" pin) 1=Set Active High; 0=Set Active Low XCK_SEL[1:0] : Driver Clock Selection 00=CLK/8; 01=CLK/4(Default); 10=CLK/2; 11=CLK The CLK means system clock SDIR:SEG Scan Direction 1=SEG order is 319~0; 0=SEG order is 0~319 CDIR: COM Scan Direction 1=COM order is 239~0; 0=COM order is 0~239
03h	ADSR	R/W	SCR_PEND	-	-	-	BIT_INV	SCR_DIR	SCR_HV	SCR_EN	SCR_PEND : scroll Function Pending 1=Scroll function pending; 0=Scroll function keep active BIT_INV : Set driver data output BIT Order 1=inverse order (BIT7 to BIT0, BIT6 to BIT1, and so on); 0=Normal order SCR_DIR : Scroll Direction When SCR_HV=1, 1= Bottom -> Top; 0= Top -> Bottom When SCR_HV=0, 1=Right -> Left; 0=Left -> Right SCR_HV : Scroll Horizontal/Vertical Selection 1= Common Scrolling(Vertical); 0= Segment Scrolling(Horizontal) SCR_EN : Scroll Enable 1=Scroll function enable; 0=Scroll function disable

Register Table Summary (cont')

Reg. Add	Reg. Name	R/W	D7	D6	D5	D4	D3	D2	D1	D0	Descriptions
0FH	INTR	R/W	1	WAKI_EN	KEYI_EN	TPI_EN	TP_ACT	WAK_STS	KEY_STS	TP_STS	<p>WAKI_EN : Wakeup Interrupt Mask 1=enable ; 0=disable</p> <p>KEYI_EN : Key-Scan Interrupt Mask 1=enable ; 0=disable</p> <p>TPI_EN : Touch Panel Interrupt Mask 1=Generate interrupt output if TP was detected; 0=disable</p> <p>TP_ACT : Touch Panel Event (only read) 1=TP is touched;0=TP is not touched</p> <p>WAK_STS : Wakeup Interrupt Status bit 1=Indicate wake-up event happen from Sleep mode 0=Indicate no wake-up happen User must write 0 to clear the status bit</p> <p>KEY_STS : Key-Scan Interrupt Status bit 1=Key-Scan Detect Key input; 0=Key-Scan don't Delete key input User must write 0 to clear the status bit</p> <p>TP_STS : Touch Panel Detect Status bit 1= TP touched; 0=TP untouched User must write 0 to clear the status bit</p>
10h	WCCR	R/W	CUR_INC	FULL_OFS	BIT_REV	BOLD	T90DEG	CUR_EN	CUR_BLK	1	<p>CUR_INC : Auto-increase Cursor Position in reading/writing DDRAM operation 1=disable; 0=enable</p> <p>FILL_OFS: Full-size and Half-size Character Alignment 1=Full-size alignment in Full-size and Half-size mixed mode; 0=disable</p> <p>BIT_REV : Reversed Data Write mode 1= inversely; 0= directly</p> <p>BOLD : Set Bold font (char mode only) 1=bold; 0=normal</p> <p>T90DEG : Font Rotate mode (Font rotated 90 degree) 1=enable; 0=normal</p> <p>CUR_EN : Cursor display control 1=on; 0=off</p> <p>CUR_BLK : Cursor blink control 1=blinking; 0=normal (Blink time is determined by REG 80H)</p>
11h	CHWI	R/W	CURH3	CURH2	CURH1	CURH0	ROWH3	ROWH2	ROWH1	ROWH0	<p>CURH[3:0] : Cursor Height (Vertical direction, horizontal is fix) 0000b : Cursor height 1pixel 0001b : Cursor height 2 pixels 1111b : Cursor height 16 pixels</p> <p>ROWH[3:0] : Char Line Gap 0000b : Char LineGap 1pixel 0001b : Char LineGap 2 pixels 1111b : Char LineGap 16 pixels</p>
12h	MAMR	R/W	CUR_HV	DISPMD2	DISPMD1	DISPMD0	L_MIX1	L_MIX0	MW_MD1	MW_MD0	<p>CUR_HV : Cursor Auto Shifting Direction(only Graphic Mode) 1= Vertical then Horizontal; 0= Horizontal then Vertical</p> <p>DISPMD[2:0] : Display Layer and Display Mode Selection 001=page1 only(default); 010=page2 only; 011=combine two layer; 000=gray scale mode 110=extended mode1, 111=extended mode2</p> <p>L_MIX[1:0] : two layer mode setting 00=OR; 01=XOR; 10=NOR; 11=AND</p> <p>MW[1:0] : Layer Read/Write Selection 00=CGRAM(512Byte); 01=page1; 10=page2; 11=page1 & page2 at the same time</p>
20h	AWRR	R/W	1	1	AWR5	AWR4	AWR3	AWR2	AWR1	AWR0	<p>AWR[5:0]: Active Window Right Position ->Segment-Right Default Value:27h</p>
21h	DWRR	R/W	1	1	DWW5	DWW4	DWW3	DWW2	DWW1	DWW0	<p>DWW[5:0] : Display Window Width Position -> Segment-Width Segment-Width = (Segment Number / 8) – 1 Default Value:27h</p>
30h	AWBR	R/W	AWB7	AWB6	AWB5	AWB4	AWB3	AWB2	AWB1	AWB0	<p>AWT[7:0] : Active Window Bottom Position->Common-Bottom Default Value: efh</p>
31h	DWHR	R/W	DWH7	DWH6	DWH5	DWH4	DWH3	DWH2	DWH1	DWH0	<p>DWH[7:0] : Display Window Bottom Position->Common-Height Common-Height = LCD Common Number – 1 Default Value: efh</p>

Register Table Summary (cont')

Reg. Add	Reg. Name	R/W	D7	D6	D5	D4	D3	D2	D1	D0	Descriptions
40h	AWLR	R/W	:	:	AWL5	AWL4	AWL3	AWL2	AWL1	AWL0	AWL[5:0] : Active Window Left Position-> Segment-Left Default Value:00h
50h	AWTR	R/W	AWT7	AWT6	AWT5	AWT4	AWT3	AWT2	AWT1	AWT0	AWT[7:0] : Active Window Top Position -> Common- Top Default Value:00h
60h	CURX	R/W	:	:	CURX5	CURX4	CURX3	CURX2	CURX1	CURX0	CURX[5:0] : Cursor Position of Segment /CGRAM address[4:0]
61h	BGSX	R/W	:	:	BGSX5	BGSX4	BGSX3	BGSX2	BGSX1	BGSX0	BGSX[5:0] : Segment Start Position of Scrolling Mode
62h	EDSX	R/W	:	:	EDSX5	EDSX4	EDSX3	EDSX2	EDSX1	EDSX0	EDSX[5:0] : Segment End Position of Scrolling Mode
70h	CURY	R/W	CURY7	CURY6	CURY5	CURY4	CURY3	CURY2	CURY1	CURY0	RC7~RC0 : Cursor Position of Common /CGRAM address[8:5]
71h	BGCM	R/W	BGCM7	BGCM6	BGCM5	BGCM4	BGCM3	BGCM2	BGCM1	BGCM0	BGCM[7:0] : Common Start Position of Scrolling Mode
72h	EDCM	R/W	EDCM7	EDCM6	EDCM5	EDCM4	EDCM3	EDCM2	EDCM1	EDCM0	EDCM[7:0] : Common Ending Position of Scrolling Mode
80h	BTMR	R/W	BLKT7	BLKT6	BLKT5	BLKT4	BLKT3	BLKT2	BLKT1	BLKT0	BLKT[7:0] : Cursor Blink Time and Scroll Time Blinking Time = Bit[7:0] x (Frame width) Frame width = 1 / Frame Rate
90h	ITCR	R/W	ITC7	ITC6	ITC5	ITC4	ITC3	ITC2	ITC1	ITC0	ITC[7:0] : Idle Time Setting, In count of system clock FR_time = COM_NO x (SEG_NO / 4 + ITC) / XCK FR_time = 1 / Frame Rate
A0h	KSCR1	R/W	KEY_EN	KEY4X8	KSAMP1	KSAMP0	LKEY_EN	KF2	KF1	KF0	KSCR1[7] : Key Scan Enable 1=enable, 0=disable KSCR1[6] : Key Scan Enable 1 : 4x8 Matrix(KOUT[3:0] is used, KOUT[7:4] please keep floating) 0 : 8x8 Matrix(KOUT[7:0] is used) KSCR1[5:4] : Key Scan Data Sampling Times 00: 4, 01: 8, 10: 16, 11:32 KSCR1[3] : Long Time Key Function 1=enable, 00=disable KSCR1[2:0] : Key Scan Freq
A1h	KSCR2	R/W	KWAK_EN	:	:	:	LKEY_T1	LKEY_T0	KEYNO1	KEYNO0	KSCR2[7] : Key Scan Wakeup Function 1=enable, 0=disable KSCR2[3:2] : Long Key Timing Adjustment KSCR2[1:0] : Number of Key Hit
A2h	KSDR0	R	KSD07	KSD06	KSD05	KSD04	KSD03	KSD02	KSD01	KSD00	KSDR0[7:0] : Key Strobe Data
A3h	KSDR1	R	KSD17	KSD16	KSD15	KSD14	KSD13	KSD12	KSD11	KSD10	KSDR1[7:0] : Key Strobe Data
A4h	KSDR2	R	KSD27	KSD26	KSD25	KSD24	KSD23	KSD22	KSD21	KSD20	KSDR2[7:0] : Key Strobe Data

Register Table Summary (cont')

B0h	MWCR	W	MWD7	MWD6	MWD5	MWD4	MWD3	MWD2	MWD1	MWD0	MWD[7:0] : The Data is written to memory under the cursor position
B1h	MRCR	R	MRD7	MRD6	MRD5	MRD4	MRD3	MRD2	MRD1	MRD0	MRD[7:0] : The Data is Read from memory under the cursor position
C0h	TPCR1	R/W	TP_EN	TP_SMP2	TP_SMP1	TP_SMP0	TPWAK_EN	ACK2	ACK1	ACK0	TPCR1[7] : Touch Panel Enable 1=enable, 0=disable TPCR1[6:4] : Touch Panel Sample Time adjustment TPCR1[3] : Touch Panel Wake-Up 1=enable, 0=disable TPCR1[2:0] : Touch Panel ADC Convert Speed
C1h	TPXR	R	TPX9	TPX8	TPX7	TPX6	TPX5	TPX4	TPX3	TPX2	TPXR[7:0] : Touch Panel X Data Bit[9:2]
C2h	TPYR	R	TPY9	TPY8	TPY7	TPY6	TPY5	TPY4	TPY3	TPY2	TPYR[7:0] : Touch Panel Y Data Bit[9:2]
C3h	TPZR	R	--	--	--	--	TPY1	TPY0	TPX1	TPX0	TPZR[3:2] : Touch Panel Y Data Bit[1:0] TPZR[1:0] : Touch Panel X Data Bit[1:0]
C4h	TPCR2	R/W	MTP_MD	--	--	--	--	--	MTP_PH1	MTP_PH2	TPCR2[7] : TP Manual Mode 1=manual mode, 0=auto mode TPCR2[1:0] : TP manual mode Options
E0h	PNTR	R/W	PND7	PND6	PND5	PND4	PND3	PND2	PND1	PND0	PND[7:0] : Data Written to DDRAM when REGF0H Bit3=1
F0h	FNCR	R/W	ISO8859_EN	--	--	--	MCLR	ASC	ASC_SEL1	ASC_SEL0	ISO8859_EN : ISO8859 Mode 1=disable; 0=enable MCLR : Memory Clear function 1=enable fill data of REG E0H to DDRAM under Active Window area; 0=no action; ASC : Font ROM range select 1=decode as ASCII; 0=auto treat as ASCII or GB ASC_SEL[1:0] : ASCII Block Selection 00=map to ASCII block 1; 01=map to ASCII block 2; 10=map to ASCII block 3; 11=map to ASCII block 4
F1h	FVHT	R/W	FH1	FH0	FV1	FV0	1	1	1	1	FH1~FV0 : Font Horizontal Size 00=1x; 01=2x; 10=3x; 11=4x FV1~FV0 : Font Vertical Size 00=1x; 01=2x; 10=3x; 11=4x

Note:

- *1. It is suggested to check the BUSY before sending the Control Data.
- *2. For the details, please refer to RA8806 Data sheet.

5. Design and Handling Precaution

Please refer to "LCD-Module-Design-Handling-Precaution.pdf".

Terminal No.	Pin Name
1	VDDUT
2	V0
3	VSS
4	VDD
5	BUSY
6	NC
7	/CS
8	RS
9	/WR
10	/RD
11	DB0
12	DB1
13	DB2
14	DB3
15	DB4
16	DB5
17	DB6
18	DB7
19	/RST
20	NC
21	BLA
22	BLK
23	BLA
24	BLK
25	BLA
26	BLK

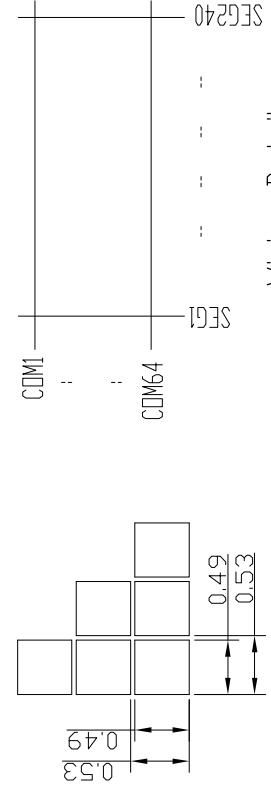
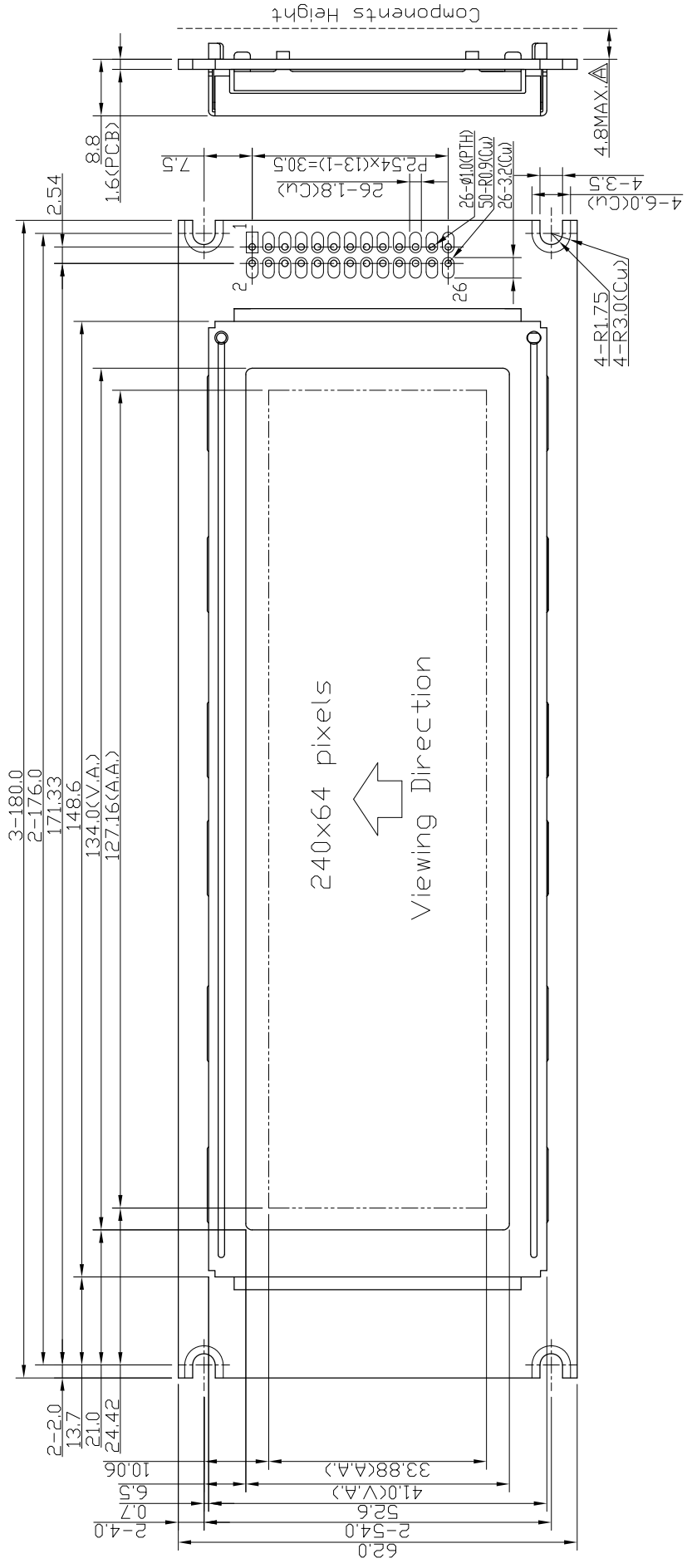

- Note:
- *1. LCD Display Type : STN-Gray, Positive, Transflective
 - *2. Viewing Direction : 6H
 - *3. Duty : 1/64
 - *4. Operating Voltage : 3.3V
 - *5. Backlight Color : White
 - *6. Backlight Supply : 3.3V TYP.
 - *7. Operating Temperature : -20°C~70°C
 - *8. Storage Temperature : -30°C~80°C
 - *9. An external VR(25K to 50K) must be connected for Contrast Control

Pixels_Details
Scale=20/1

Wiring_Details
Scale=free

C				
B				
A	Revise Components Height	Rev. No.	MK-003505a-1-1	Date
		Rev. Note		2019-06-03
		Dwg Title	LM6066R0DW Outline Dwg	Date
		Dwg No.	MK-003505a-1-1	2010-12-20
		Scale	7/5	Unit
			±0.5	mm
		Approved		Checked
				Drawn
				Yang Lin

TOPWAY