



深圳市拓普微科技开发有限公司

SHENZHEN TOPWAY TECHNOLOGY CO., LTD.

LM24064JFW

LCD Module User Manual

Prepared by: Li KeKe Date: 2021-04-19	Checked by: Date:	Approved by: Date:
--	----------------------------------	-----------------------------------

Rev.	Descriptions	Release Date
0.1	Preliminary release	2013-05-10
0.2	Add MTBF value,LED Backlight Life Time and Contrast Ratio.	2013-05-14
0.3	Change the outline demision and Update the AC characteristics.	2014-02-16
0.4	Update 1.4 and add outline drawing	2021-04-19

Table of Content

1. Basic Specifications.....	3
1.1 Display Specifications.....	3
1.2 Mechanical Specifications.....	3
1.3 Block Diagram.....	3
1.4 Terminal Functions(FPC).....	4
1.5 Backlight Terminal.....	4
2. Absolute Maximum Ratings.....	5
3. Electrical Characteristics.....	5
3.1 DC Characteristics.....	5
3.2 LED Backlight Circuit Characteristics.....	5
3.3 AC Characteristics.....	6
3.4 Reset Timing.....	8
4. Optical Characteristics.....	9
4.1 Optical Characteristics.....	9
4.2 Definition.....	9
5. Function Specifications.....	11
5.1 Adjusting the Display Contrast.....	11
5.2 Resetting the LCD module.....	11
5.3 Application circuit (Example).....	11
5.4 Display Memory Map.....	12
5.5 Commands.....	13
5.6 Command Table.....	16
6. Design and Handling Precaution.....	17

1. Basic Specifications

1.1 Display Specifications

- 1) LCD Display Mode : STN,Blue,Negative, Transmissive
- 2) Display Color : Display Data = "1" : Light Gray (*1)
: Display Data = "0" : Dark Gray (*2)
- 3) Viewing Angle : 6H
- 4) Driving Method : 1/64 duty, 1/10 bias
- 5) Back Light : White LED backlight

Note:

*1. Color tone may slightly change by Temperature and Driving Condition.

*2. The Color is defined as the inactive / background color

*3. Fine Contrast adjustment function is necessary in the application design for optimal display result

1.2 Mechanical Specifications

- 1) Outline Dimension : 156.0x 52.0 x 12.0 (Exclude FPC)
(See attached Outline Drawing for details)

1.3 Block Diagram

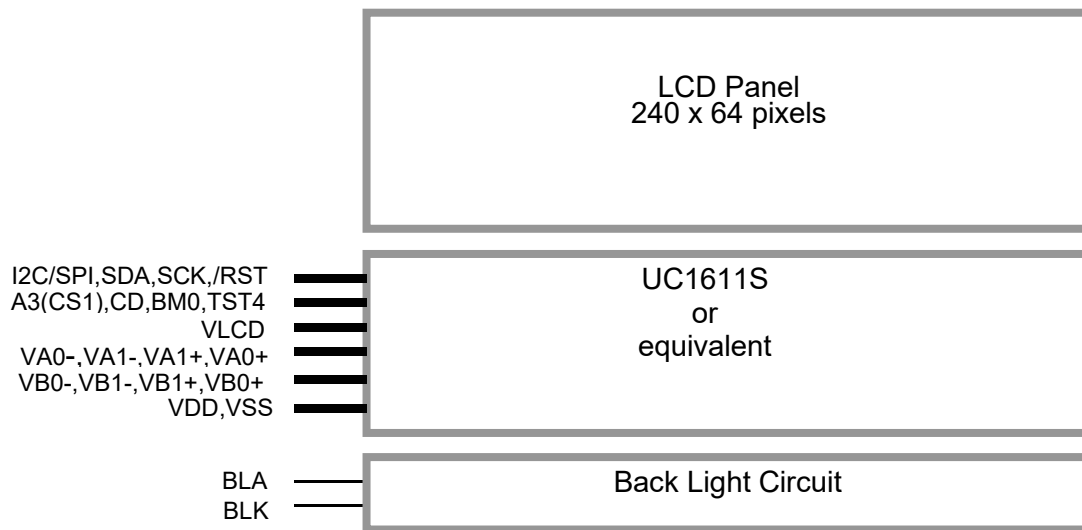

1.4 Terminal Functions(FPC)

Pin No.	Pin Name	I/O	Descriptions		
			3-Wire SPI-S9 (Default)	4-Wire SPI(S8)	2-Wire SPI(IIC)
1	VB0+	Power	DC-DC Booster capacitors Control data or Display data Selection for read/write operation. In S9 and I2C mode,CD pin is not used,connect CD pin to Vss. “L”:Control data “H”:Display data		
2	VB1+				
3	VB1-				
4	VB0-				
5	VA0+				
6	VA1+				
7	VA1-				
8	VA0-				
9	VLCD	Power	LCD power supply		
10	VDD	Power	Positive Power Supply		
11	VSS	Power	0V Supply, Ground (0V)		
12	VSS	Power	0V Supply, Ground (0V)		
13	TST4	Input	Normal leave open		
14	BM0	Input	H	L	H
15	CD	Input	Not used, please connect to VSS.	Control data or Display data selection for ‘Read’ or ‘Write’ operation. “L”:Control data “H”:Display data	Not used, please connect to VSS.
16	A3(CS1)	Input	Chip Select CS1=H, enable access to the LCD module CS1=L, disable access to the LCD module		Use to configure the address of the device
17	/RST	Input	Rest input pin,when /RST is“L”,initialization is excuted		
18	SCK	Input	Serial clock input		
19	SDA	Input	Serial data input		
20	I ² C/SPI	Input	L	L	H

1.5 Backlight Terminal

Pin No.	Pin Name	I/O	Descriptions	Wire color
1	BLA	Power	Backlight positive power supply	Red
2	BLK	Power	Backlight negative power supply	white

2. Absolute Maximum Ratings

Items	Symbol	Min.	Max.	Unit	Condition
Supply Voltage	V_{DD}	-0.3	+4.0	V	$V_{SS} = 0V$
Input Voltage	V_{IN}	-0.3	$V_{DD}+0.3$	V	$V_{SS} = 0V$
Operating Temperature	T_{OP}	-20	+70	°C	No Condensation
Storage Temperature	T_{ST}	-30	+80	°C	No Condensation
Mean Time Between Failure	MTBF	100000	-	HRS	No Condensation

Cautions:

Any Stresses exceeding the Absolute Maximum Ratings may cause substantial damage to the device. Functional operation of this device at other conditions beyond those listed in the specification is not implied and prolonged exposure to extreme conditions may affect device reliability.

3. Electrical Characteristics

3.1 DC Characteristics

$V_{SS}=0V, V_{DD}=3.3V, T_{OP}=25^{\circ}C$

Items	Symbol	MIN.	TYP.	MAX.	Unit	Condition / Application Pin
Operating Voltage	V_{DD}	3.0	3.3	3.6	V	VDD
Input High Voltage	V_{IH}	$0.8 \times V_{DD}$	-	V_{DD}	V	SDA,SCK, /RST,CS1,CD
Input Low Voltage	V_{IL}	0	-	$0.2 \times V_{DD}$	V	
Operating Current	I_{DD}	-	0.63	1.6	mA	VDD

3.2 LED Backlight Circuit Characteristics

$V_{SS}=0V, I_{f_{BLA}}=136mA, T_{OP}=25^{\circ}C$

Items	Symbol	MIN.	TYP.	MAX.	Unit	Applicable Pin
Forward Voltage	$V_{f_{BLA}}$	-	3.3	-	V	BLA
Forward Current	$I_{f_{BLA}}$	-	136	160	mA	BLA
Life Time	-	-	50000	-	HRS	

Cautions:

Exceeding the recommended driving current could cause substantial damage to the backlight and shorten its lifetime.

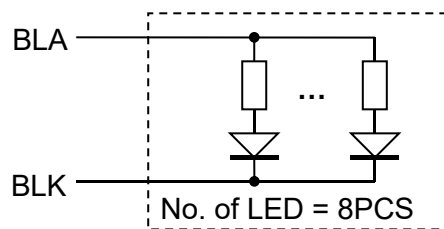

3.3 AC Characteristics

3.3.1 3-Wire Serial Interface(Default)

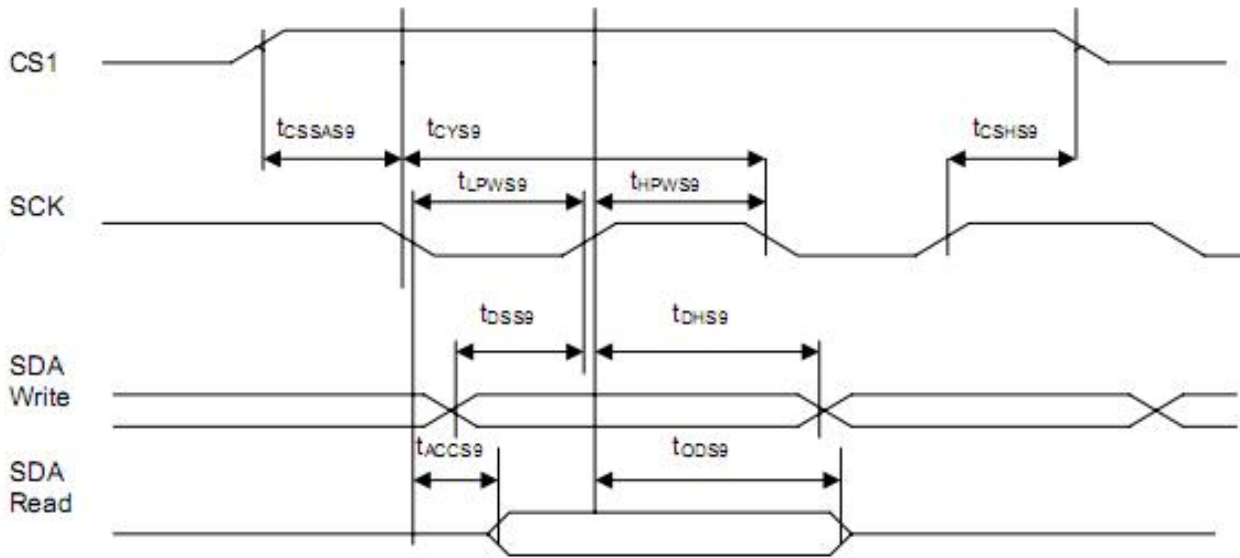

$V_{SS}=0V, V_{DD}=3.3V, T_{OP}=25^{\circ}C$

Item	Symbol	MIN.	TYP.	MAX.	Unit
System cycle tim (Read/Write)	t_{CYS9}	156/46	-	-	ns
Low pulse width (Read/Write)	T_{LPWS9}	78/23	-	-	ns
High pulse width (Read/Write)	T_{HPWS9}	78/23	-	-	ns
Read access time	T_{ACCS9}	-	-	35	ns
Output disable time(Read)	T_{ODS9}	20	-	-	ns
Data setup time(Write)	T_{DSS9}	20	-	-	ns
Data hold time (Write)	T_{DHS9}	0	-	-	ns
Chip select setup time	T_{CSSAS9}	0	-	-	ns
	T_{CSHS9}	0	-	-	ns

3.3.2 4-Wire Serial Interface

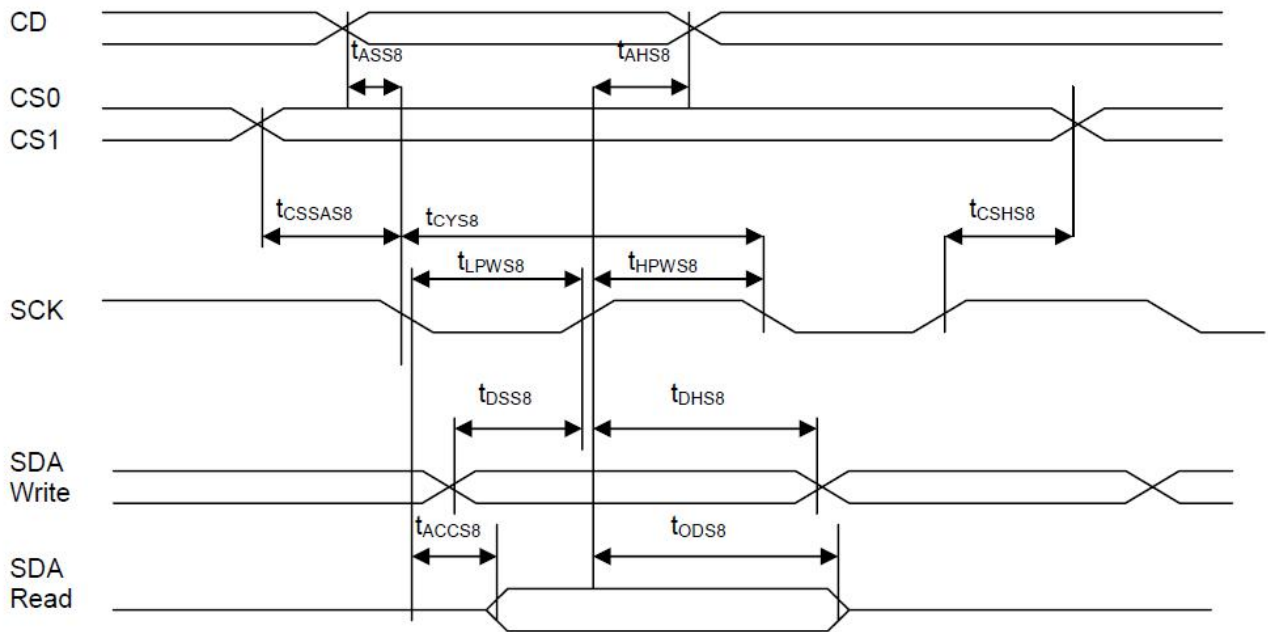

$V_{SS}=0V, V_{DD}=3.3V, T_{OP}=25^{\circ}C$

Item	Symbol	MIN.	TYP.	MAX.	Unit
Address setup time	t_{ASS8}	0			
Address hold time	t_{AHS8}	0			
System cycle tim (Read/Write)	t_{CYS8}	156/46	-	-	ns
Low pulse width (Read/Write)	T_{LPWS8}	78/23	-	-	ns
High pulse width (Read/Write)	T_{HPWS8}	78/23	-	-	ns
Read access time	T_{ACCS8}	-	-	35	ns
Output disable time(Read)	T_{ODS8}	20	-	-	ns
Data setup time(Write)	T_{DSS8}	20	-	-	ns
Data hold time (Write)	T_{DHS8}	0	-	-	ns
Chip select setup time	T_{CSSAS8}	0	-	-	ns
	T_{CSHS8}	0	-	-	ns

3.3.3 I²C mode Interface

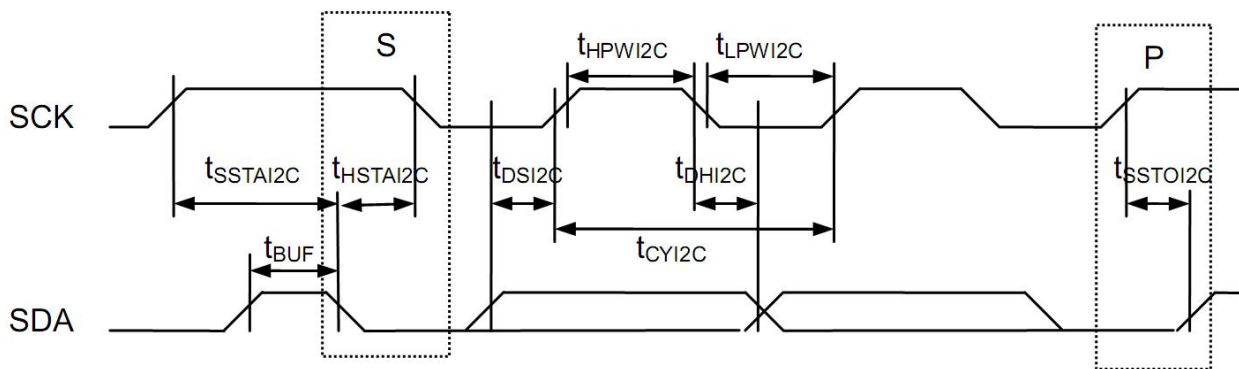

$V_{SS}=0V, V_{DD}=3.3V, T_{OP}=25^{\circ}C$

Item	Symbol	MIN.	TYP.	MAX.	Unit
SCK cycle time (Read/Write)	t_{CYI2C}	754/360	-	-	ns
Low pulse width (Read/Write)	t_{LPWI2C}	377/180	-	-	ns
High pulse width (Read/Write)	t_{HPWI2C}	377/180	-	-	ns
Data setup time	t_{DSI2C}	43	-	-	ns
Data hold time	t_{DHI2C}	15	-	-	ns
START Setup time	$t_{SSTAI2C}$	36	-	-	ns
START Hold time	$t_{HSTAI2C}$	65	-	-	ns
STOP setup time	$t_{SSTOI2C}$	36	-	-	ns
Bus Free time	t_{BUF}	215	-	-	ns

Note:

*1. Input signal rise/fall time should be less than 70ns

*2. Other kind of serial mode, please refer to the datasheet of UC1611S

3.4 Reset Timing

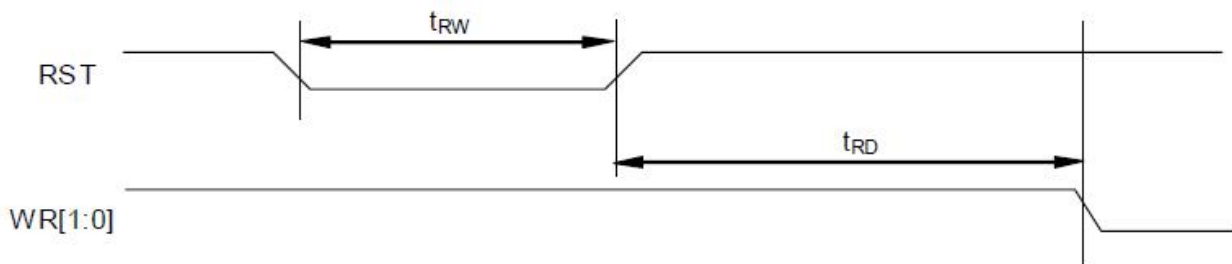

$V_{SS}=0V, V_{DD}=3.3V, T_{OP}=25^{\circ}C$

Item	Symbol	MIN.	TYP.	MAX.	Unit
Reset low pulse width	t_{RW}	4	-	-	us
Reset to WR pulse delay	t_{RD}	13	-	-	ms

4. Optical Characteristics

4.1 Optical Characteristics

T_{OP} =25°C

Item	Symbol	MIN.	TYP.	MAX.	Unit	note
Viewing Direction	Φ	-	6H	-	-	Vop=typ.
On Time	ton	-	82	-	ms	$\theta X, \theta Y = 0^\circ$, Vop=typ.
Off Time	toff	-	135	-	ms	$\theta X, \theta Y = 0^\circ$, Vop=typ.
LCD Operating Voltage	Vop	-	13	-	V	$\theta X, \theta Y = 0^\circ$
View Angle	$\theta 3H$	-	37	-	deg	Contrast>40%MCR *1
	$\theta 9H$	-	36	-	deg	
	$\theta 6H$	-	45	-	deg	
	$\theta 12H$	-	38	-	deg	
Contrast ratio	Cr	--	3	--		Contrast ratio

Note:

*1 MCR=Display Maximum Contrast Ratio

4.2 Definition

4.2.1 Viewing Direction

Viewing Direction = direction (Φ) that provide the best display result

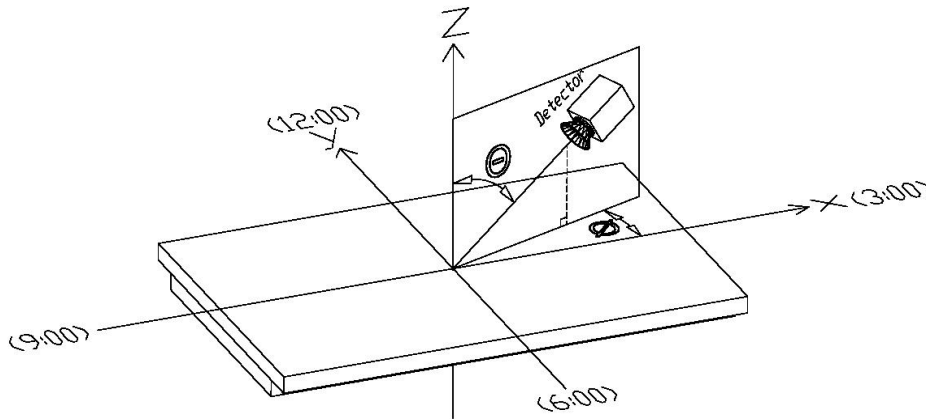

4.2.2 Response Time

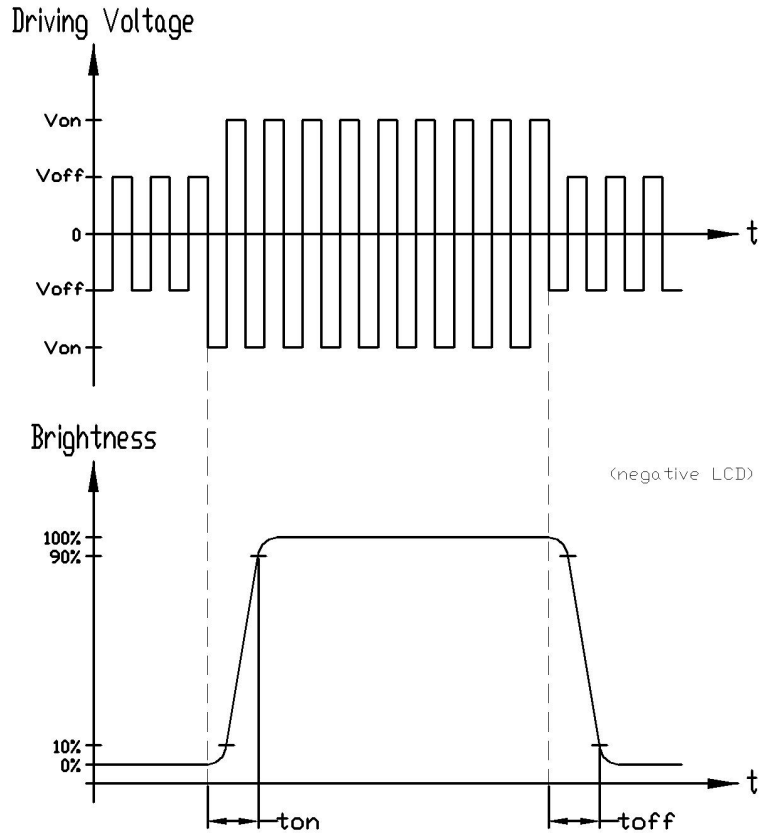

5. Function Specifications

5.1 Adjusting the Display Contrast

- This LCD module equipped with latest digital contrast adjustment function.
- Its display contrast could be adjusted by MCU command. (please see the command tables for details)

It is recommended to provide a contrast adjustment interface for end-user, where the best display result could meet the individual preference in mass production.

5.2 Resetting the LCD module

The LCD module should be initialized by using /RST terminal. While turning on the VDD and VSS power supply, maintain /RST terminal at LOW level. After the power supply stabilized, release the reset terminal (/RST=HIGH)

5.3 Application circuit (Example)

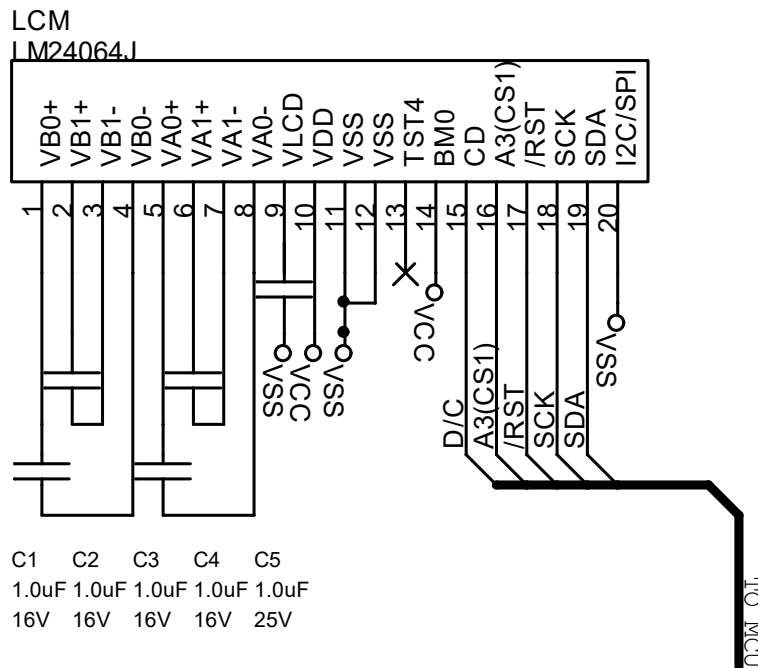

NOTE:

- *1. Using internal step up booster
- *2. 3 wire serial mode

5.4 Display Memory Map

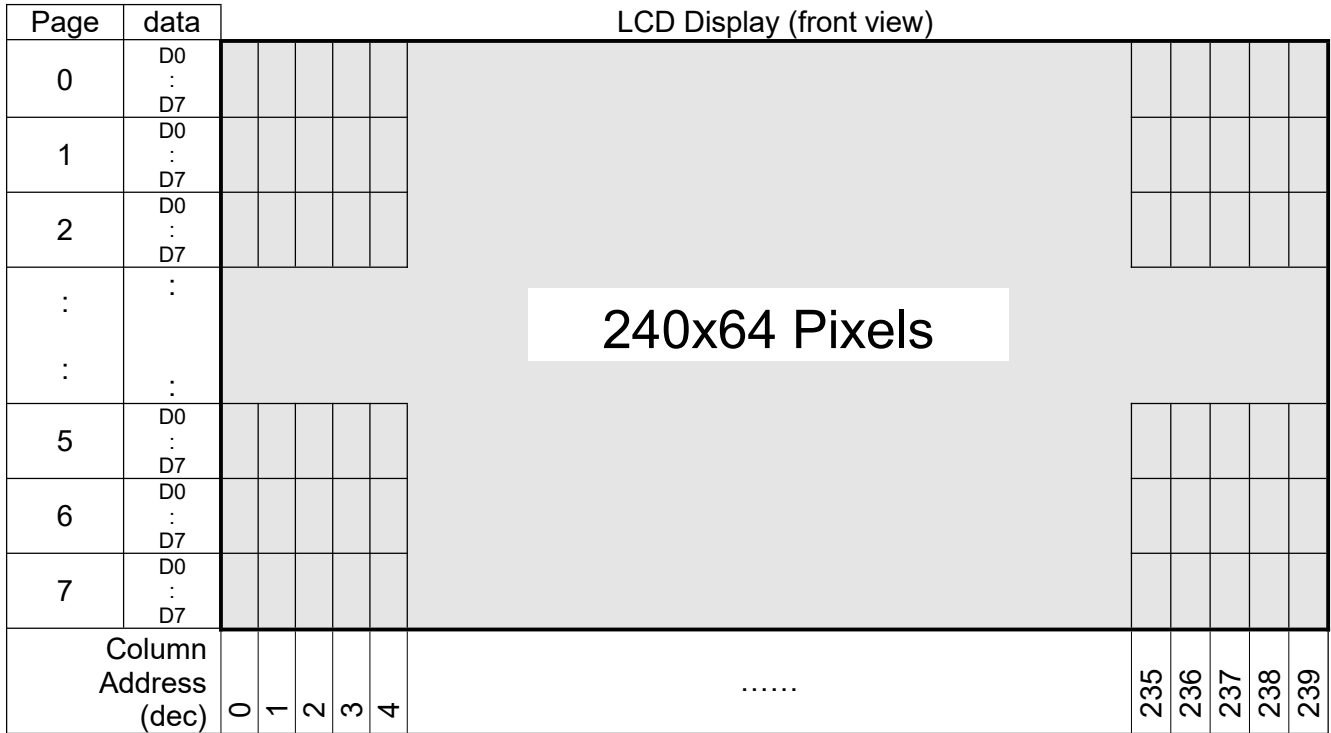

Pixel mapping (Top View)

Note:

- *1. Based on the top view of the LCD module,
- *2. The above is memory map based on:
 On/Off mode setting, DC[5:3]=100 (1bpp), the Page value range:0~7
 LC[0]=MSF=0
 LC[1]=MX=1
 LC[2]=MY=0
 SL=0
- *3. For 4,8 and 16 Gray-shade operation please refer to UC1611S datasheet.

5.5 Commands

5.5.1 Register Table

Name	Bits	Default	Description
SL	8	00H	Scroll Line. Scroll the displayed image up by SL rows. The valid SL value are between 0 (for no scrolling) and (159 – FL). Setting SL outside of this range causes undefined effect on the displayed image.
FL	4	0H	Fixed lines. The first (FLx2) lines of each frame are fixed and are not affected by scrolling (SL). When FL is non-zero, the screen is effectively separated into two regions: one scrollable, one non-scrollable.
CA	8	00H	Display Data RAM Column Address (Used in Host to Display Data RAM access)
PA	7	00H	Display Data RAM Page Address (Used in Host for Display Data RAM access) When DC[5:3] = 100b, PA[6:5] : used to select Write Pattern 0~3. PA[4:0] : set SRAM page address
BR	2	2H	Bias Ratio. The ratio between V_{LCD} and V_{BIAS} . 00b: 5 01b: 10 10b: 11 11b: 12
TC	2	0H	Temperature Compensation (per °C). 00b: -0.05% 01b: -0.10% 10b: -0.15% 11b: 0.00%
PM	8	EAH	Electronic Potentiometer to fine tune V_{BIAS} and V_{LCD}
PMO	6	00H	PM offset. the effective PM value, $PMV = PM - PMO[4:0]$ when $PMO[5]=1$ the effective PM value, $PMV = PM + PMO[4:0]$ when $PMO[5]=0$
PC	4	FH	Pump Control. PC[1:0]: Panel Loading 00b: LCD: $\leq 33nF$ 11b: $33nF \leq LCD \leq 55nF$ PC[3:2]: Pump Control 00b: External V_{LCD} 11b: Internal V_{LCD} (11x charge pump) (Setting to 01 or 10 will be invalid and default value will be used instead.)
AC	4	1H	Address Control: AC[0]: WA: Automatic column/page Wrap Around (Default 1:ON) AC[1]: Auto-Increment order 0: Column (CA) first 1: Page (PA) first AC[2]: PID: PA (page address) auto increment direction (0:+1, 1:-1) AC[3]: Window Program Mode 0: Inside Mode: Write to SRAM within the window defined by (WPC0,WPP0), (WPC1,WPP1) 1: Outside Mode: Write to SRAM but skip the window defined by (WPC0,WPP0), (WPC1,WPP1)

Register Table (continue)

Name	Bits	Default	Description																									
DC	8	18H	Display Control: DC[0]: PXV: Pixels Inverse. Bit-wise data inversion. (Default 0:OFF) DC[1]: APO: All Pixels ON (Default 0:OFF) DC[2]: Display ON/OFF (Default 0:OFF) DC[4:3]: Gray-shade Modulation mode. 00 : On/Off mode 01: 8-shade Mode 10 : 4-shade Mode 11: 16-shade mode DC[5]: Input Type of On/Off Mode (enable only when DC[4:3]=00b) 0: 4-bit per 1-pixel 1: 1-bit per 1-pixel DC[7:6]: Display Pattern Selection (enable only when DC[5:3]=100b) 00: Pattern0 01: Pattern1 10: Pattern2 11: Pattern3																									
LC	10	020H	LCD Control: LC[0]: MSF: MSB First mapping Option (Default: 0:OFF) LC[1]: MX, Mirror X. SEG/Column sequence inversion (Default: 0:OFF) LC[2]: MY, Mirror Y. COM/Row sequence inversion (Default: 0:OFF) LC[3]: Enable FL lines in partial display mode.(Default: 0:OFF) LC[5:4]: Line Rate (= Frame-Rate x Mux-Rate) <table border="1" style="margin-left: 20px; margin-top: 10px;"> <thead> <tr> <th></th> <th>LC[5:4]=00b</th> <th>01b</th> <th>10b</th> <th>11b</th> </tr> </thead> <tbody> <tr> <td>16-shade</td> <td>20.0 Klps</td> <td>24.0</td> <td>28.0</td> <td>32.0</td> </tr> <tr> <td>8-shade</td> <td>14.1</td> <td>16.9</td> <td>19.7</td> <td>22.5</td> </tr> <tr> <td>4-shade</td> <td>13.3</td> <td>16.0</td> <td>18.7</td> <td>21.4</td> </tr> <tr> <td>On/Off mode</td> <td>5.9</td> <td>7.1</td> <td>8.2</td> <td>9.4</td> </tr> </tbody> </table> <p style="text-align: right;">(Klps: Kilo-Line-per-second)</p> LC[7:6]: Reserved (Default : 00b) LC[9:8]: Partial Display Control 0xb: Disable Mux-rate = CEN+1 (DST and DEN are not used.) 11b: Enabled Mux-rate = DEN-DST+1+LC[3]xFLx2		LC[5:4]=00b	01b	10b	11b	16-shade	20.0 Klps	24.0	28.0	32.0	8-shade	14.1	16.9	19.7	22.5	4-shade	13.3	16.0	18.7	21.4	On/Off mode	5.9	7.1	8.2	9.4
	LC[5:4]=00b	01b	10b	11b																								
16-shade	20.0 Klps	24.0	28.0	32.0																								
8-shade	14.1	16.9	19.7	22.5																								
4-shade	13.3	16.0	18.7	21.4																								
On/Off mode	5.9	7.1	8.2	9.4																								
NIV	7	00H	N-Line Inversion NIV[5:0] : 000000b : Disable N-line Inversion NIV[6] : 0b: no-XOR 1b: XOR																									
CEN	8	9FH	COM scanning ENd (the last COM with full line cycle, 0-based index) Display SStart (the first COM with active scan pulse, 0-based index) Display EDd (the last COM with active scan pulse, 0-based index) Please maintain the following relationship: CEN = (the actual number of pixel rows on the LCD) – 1 CEN ≥ DEN ≥ DST+ 9																									
DST	8	00H																										
DEN	8	9FH																										
ISOF	4	1H	Set the ISOLation clock in Front of COM pulse.																									
ISOB	4	0H	Set the ISOLation clock in Back of COM pulse.																									
WPC0	8	00H	Window program starting column address. Value range: 0 ~255.																									
WPP0	6	00H	Window program starting row address. Value range: 0~79. When DC[5:3]=100b, value range: 0~19																									
WPC1	8	FFH	Window program ending column address. Value range: 0~255.																									
WPP1	6	4FH	Window program ending row address. Value range: 0~79. When DC[5:3]=100b, value range: 0~19																									

Register Table (continue)

Name	Bits	Default	Description
MTPC	5	10H	MTP Programming Control: MTPC[2:0] : MTP command 000 : Idle 001 : Read 010 : Erase 011 : Program 1xx : For UltraChip debug use only MTPC[3] : MTP Enable (automatically cleared after each MTP command) MTPC[4] : Ignore/Use MTP. 0: Ignore 1: Use
MTPM	6	00H	MTP Write Mask.. 0: no action 1: program
APC	1	N/A	Advanced Product Configuration. For UltraChip only. Please do not use.
Status Registers			
OM	2	–	Operating Modes (Read Only) 00b: Reset 01b: (Not used) 10b: Sleep 11b: Normal
MD	1	–	MTP option flag. 0 : for non-MTP version. 1 : for MTP version
MS	1	–	MTP programming in-progress
WS	1	–	MTP Operation Succeeded

5.6 Command Table

The following setting should be issue to LCD module after hardware reset.
(It is an example only; it could be adjusted if necessary.)

Command	C/D	W/R	D7	D6	D5	D4	D3	D2	D1	D0	Action	Default	
1. Write Data Byte	1	0	#	#	#	#	#	#	#	#	Write 1 byte	N/A	
2. Read Data Byte	1	1	#	#	#	#	#	#	#	#	Read 1 byte	N/A	
3. Get Status	0	1	Ver	MX	MY	WA	DE	WS	MD	MS	Get Status	N/A	
			ID[1:0]			PMCO[5:0]			0	0			0
4. Set Column Addr. LSB	0	0	0	0	0	0	#	#	#	#	Set CA[3:0]	0	
Set Column Addr. MSB	0	0	0	0	0	1	#	#	#	#	Set CA[7:4]	0	
5. Temp. Compensation.	0	0	0	0	1	0	0	1	#	#	Set TC[1:0]	00b: -0.05%/°C	
6. Set Panel Loading	0	0	0	0	1	0	1	0	#	#	Set PC [1:0]	11b: 33-55 nF	
7. Set Pump Control	0	0	0	0	1	0	1	1	#	#	Set PC [3:2]	11b	
8. Set Adv. Program Control (double-byte command)	0	0	0	0	1	1	0	0	R	R	Set APC[R][7:0] R = 0-3	N/A	
			#	#	#	#	#	#	#	#			#
9. Set Scroll Line LSB	0	0	0	1	0	0	#	#	#	#	Set SL[3:0]	0	
Set Scroll Line MSB			0	1	0	1	#	#	#	#	Set SL[7:4]	0	
10. Set Page Address LSB	0	0	0	1	1	0	#	#	#	#	Set PA[3:0]	0	
Set Page Address MSB			0	1	1	1	0	#	#	#	Set PA[6:4]	0	
11. Set Potentiometer (double-byte command)	0	0	1	0	0	0	0	0	0	1	Set PM[7:0]	PM=EAH	
			#	#	#	#	#	#	#	#			#
12. Set Isolation Clock Front	0	0	1	0	0	0	0	0	1	0	Set ISOF[3:0]	1H	
			0	0	0	1	0	0	1	1			
			-	-	-	-	#	#	#	#			
13. Set Isolation Clock Back	0	0	1	0	0	0	0	0	1	0	Set ISOB[3:0]	0H	
			0	0	0	1	0	1	0	0			
			-	-	-	-	#	#	#	#			
14. Set Partial Display Control	0	0	1	0	0	0	0	1	#	#	Set LC[9:8]	00b: Disable	
15. Set RAM Address Control	0	0	1	0	0	0	1	#	#	#	Set AC[2:0]	001b	
16. Set Fixed Lines	0	0	1	0	0	1	#	#	#	#	Set FL[3:0]	0	
17. Set Line Rate	0	0	1	0	1	0	0	0	#	#	Set LC[5:4]	10b:28kips	
18. Set All-Pixel-ON	0	0	1	0	1	0	0	1	0	#	Set DC[1]	0	
19. Set Inverse Display	0	0	1	0	1	0	0	1	1	#	Set DC[0]	0	
20. Set Display Enable	0	0	1	0	1	0	1	#	#	#	Set DC[4:2]	110b	
21. Set LCD Mapping Control (double-byte command)	0	0	1	1	0	0	0	0	0	0	Set LC[3:0]	0	
			0	0	0	0	#	#	#	#			
22. Set N-line Inversion (double-byte command)	0	0	1	1	0	0	1	0	0	0	Set NIV[6:0]	00H	
			-	#	#	#	#	#	#	#			
23. Set Display Pattern	0	0	1	1	0	1	0	#	#	#	Set DC[7:5]	000b	
24. System Reset	0	0	1	1	1	0	0	0	1	0	System Reset	N/A	
25. NOP	0	0	1	1	1	0	0	0	1	1	No operation	N/A	
26. Set test control (double-byte command)	0	0	1	1	1	0	0	1	TT		For testing only. Do not use.	N/A	
			0	0	#	#	#	#	#	#			
27. Set LCD Bias Ratio	0	0	1	1	1	0	1	0	#	#	Set BR[1:0]	10b: 11	
28. Set COM End	0	0	1	1	1	1	0	0	0	1	Set CEN[7:0]	159	
			#	#	#	#	#	#	#	#			
29. Set Partial Display Start	0	0	1	1	1	1	0	0	1	0	Set DST[7:0]	0	
			#	#	#	#	#	#	#	#			
30. Set Partial Display End	0	0	1	1	1	1	0	0	1	1	Set DEN[7:0]	159	
			#	#	#	#	#	#	#	#			
31. Set Window Program Starting Column Address	0	0	1	1	1	1	0	1	0	0	Shared with MTP Commands	Set WPC0	0
			#	#	#	#	#	#	#	#			
32. Set Window Program Starting Row Address	0	0	1	1	1	1	0	1	0	1	Shared with MTP Commands	Set WPP0	0
			-	-	#	#	#	#	#	#			
33. Set Window Program Ending Column Address	0	0	1	1	1	1	0	1	1	0	Shared with MTP Commands	Set WPC1	255
			#	#	#	#	#	#	#	#			
34. Set Window Program Ending Column Address	0	0	1	1	1	1	0	1	1	1	Shared with MTP Commands	Set WPP1	79
			-	-	#	#	#	#	#	#			
35. Window Program Mode	0	0	1	1	1	1	1	0	0	#	Set AC[3]	0:Inside	
36. Set MTP Operation Control	0	0	1	0	1	1	1	0	0	0	Set MTPC[5:0]	10H	
			-	-	#	#	#	#	#	#			
37. Set MTP Write Mask	0	0	1	0	1	1	1	0	0	1	Set MTPM[5:0]	0	
			-	-	#	#	#	#	#	#			
38. Set V _{MTP1} Potentiometer	0	0	1	1	1	1	0	1	0	0	Shared with Window Program Commands	Set MTP1	N/A
			#	#	#	#	#	#	#	#			
39. Set V _{MTP2} Potentiometer	0	0	1	1	1	1	0	1	0	1	Shared with Window Program Commands	Set MTP2	N/A
			#	#	#	#	#	#	#	#			
40. Set MTP Write Timer	0	0	1	1	1	1	0	1	1	0	Shared with Window Program Commands	Set MTP3	N/A
			#	#	#	#	#	#	#	#			
41. Set MTP Read Timer	0	0	1	1	1	1	0	1	1	1	Shared with Window Program Commands	Set MTP4	N/A
			#	#	#	#	#	#	#	#			
SERIAL READ COMMAND (ENABLE IN S8 OR S9 BUS MODES ONLY)													
42. Get Status	0	1	1	1	1	1	1	1	1	0	Get Status till Chip Disable	N/A	
			Ver	MX	MY	WA	DE	WS	MD	MS			
			ID[1:0]			PMCO[5:0]			0	0			0

Note:

Please refer to UC1611S data sheet for details

R/W=0 means it is a write function, R/W=1 means it is a read function

C/D=0 means it is a control data, C/D=1 means it is a display data

6. Design and Handling Precaution

1. The LCD panel is made by glass. Any mechanical shock (eg. dropping from high place) will damage the LCD module.
2. Do not add excessive force on the surface of the display, which may cause the Display color change abnormally.
3. The polarizer on the LCD is easily get scratched. If possible, do not remove the LCD protective film until the last step of installation.
4. Never attempt to disassemble or rework the LCD module.
5. Only Clean the LCD with Isopropyl Alcohol or Ethyl Alcohol. Other solvents (eg. water) may damage the LCD.
6. When mounting the LCD module, make sure that it is free from twisting, warping and distortion.
7. Ensure to provide enough space (with cushion) between case and LCD panel to prevent external force adding on it, or it may cause damage to the LCD or degrade the display result.
8. Only hold the LCD module by its side. Never hold LCD module by add force on the heat seal or TAB.
9. Never add force to component of the LCD module. It may cause invisible damage or degrade of the reliability.
10. LCD module could be easily damaged by static electricity. Be careful to maintain an optimum anti-static work environment to protect the LCD module.
11. When peeling off the protective film from LCD, static charge may cause abnormal display pattern. It is normal and will resume to normal in a short while.
12. Take care and prevent get hurt by the LCD panel sharp edge.
13. Never operate the LCD module exceed the absolute maximum ratings.
14. Keep the signal line as short as possible to prevent noisy signal applying to LCD module.
15. Never apply signal to the LCD module without power supply.
16. IC chip (eg. TAB or COG) is sensitive to the light. Strong lighting environment could possibly cause malfunction. Light sealing structure casing is recommend.
17. LCD module reliability may be reduced by temperature shock.
18. When storing the LCD module, avoid exposure to the direct sunlight, high humidity, high temperature or low temperature. They may damage or degrade the LCD module

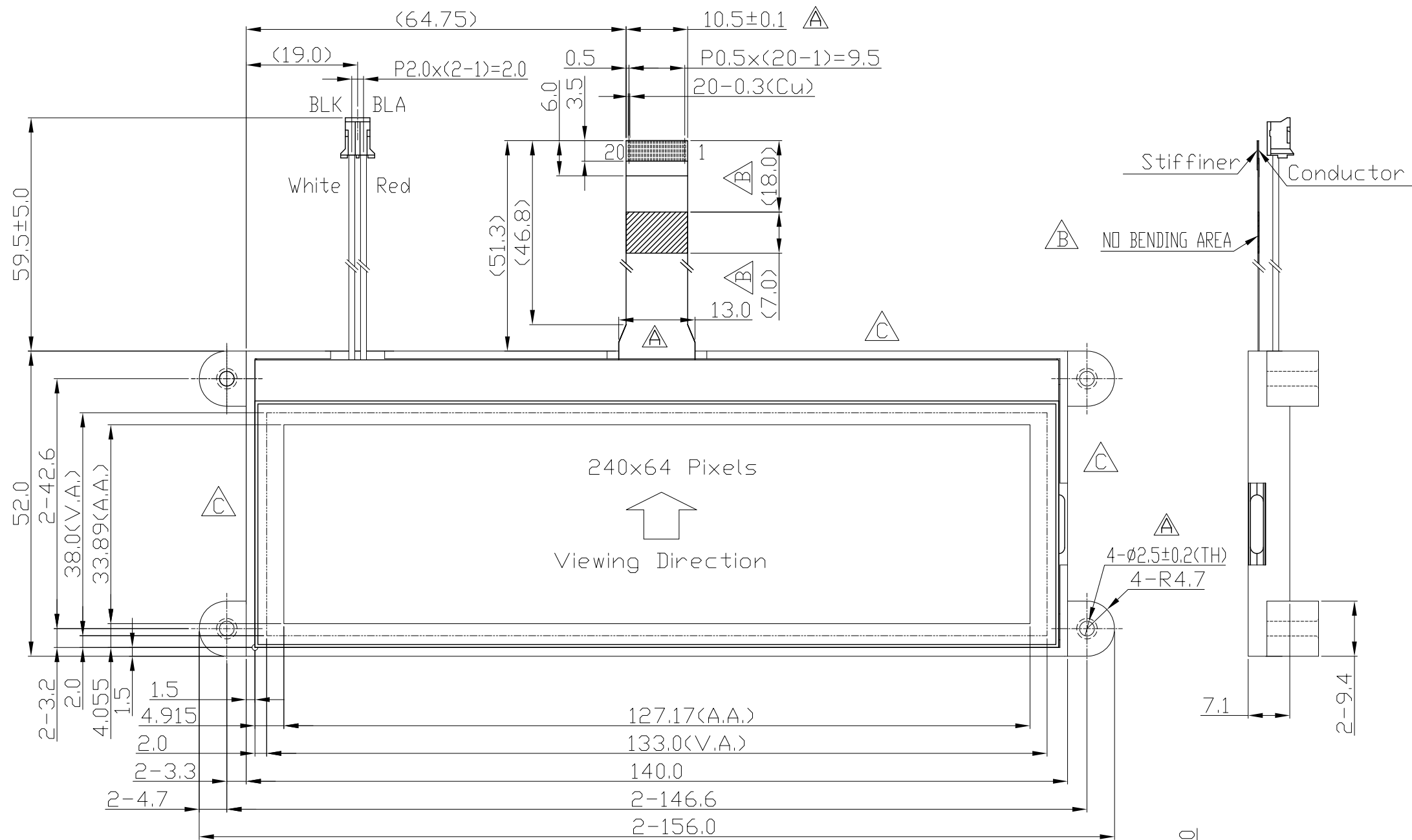

Terminal	
No.	Pin Name
1	VB0+
2	VB1+
3	VB1-
4	VB0-
5	VA0+
6	VA1+
7	VA1-
8	VA0-
9	VLCD
10	VDD
11	VSS
12	VSS
13	TST4
14	BM0
15	CD
16	A3(CS1)
17	/RST
18	SCK
19	SDA
20	I2C/SPI

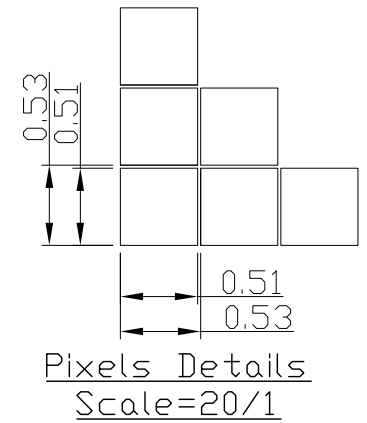

- Note:
- *1. Display Type : STN-Blue, Negative, Transmissive
 - *2. Viewing Direction : 6H
 - *3. Duty : 1/64, Bias : 1/10
 - *4. Operating Voltage : 3.3V
 - *5. Backlight Color : White
 - *6. Backlight Supply : 3.3V
 - *7. Operating Temperature : -20°C~70°C
 - *8. Storage Temperature : -30°C~80°C

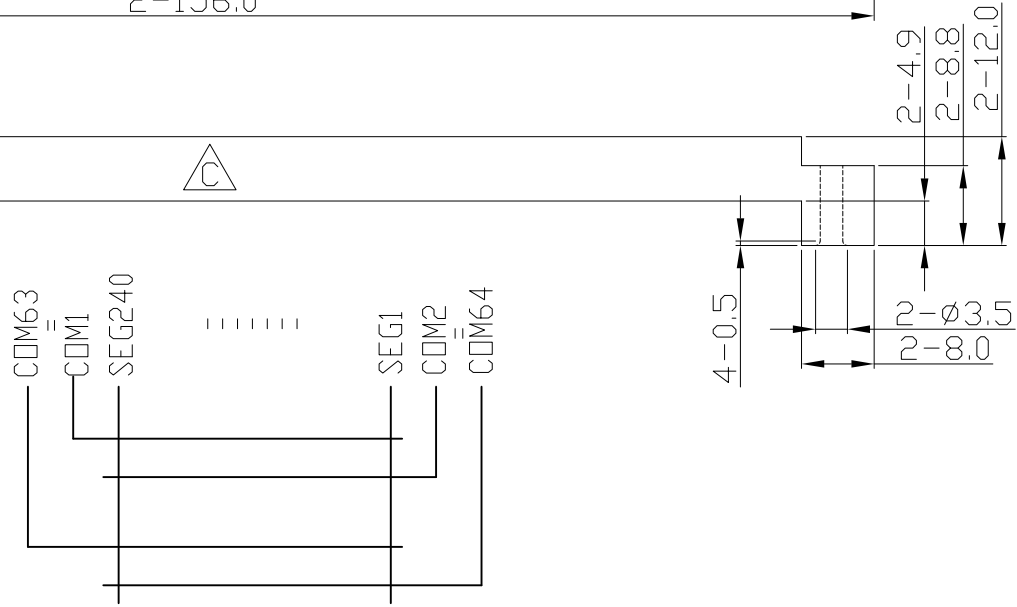

Wiring Details(Top View)
Scale=free

C	Revise Outline	Li Jiang	2014-02-12
B	Revise FPC Outline	Chen Ji	2013-05-03
A	Add Tol. Refine Structure Dwg	Chen Ji	2013-03-06
RevNote		Date	
Dwg Title LM24064JFW Outline Dwg			
Dwg No. MK-004330c-1-1		Date 2013-03-01	
Scale 6/5	Tol. ±0.3△	Unit mm	Paper Size A3
Approved	Checked	Drawn Chen Ji	

TOPWAY